

TrackMaker : : : : : : : :
NAV601
Version 1.34
*for Windows CE.NET and
Allegro CX Field Computer*

data acquisition & navigation software for
the Bartington Grad601 and GPS receiver

User's Manual

GEOMAR SOFTWARE INC.
Tel: 905.306.9215
Fax: 905.276.8158
E-mail: geomar@geomar.com

Copyright © 2008-2010, Geomar Software Inc. All rights reserved.

Revision 1.34 — April 8, 2010

This manual may not, in whole or in part, be copied, photocopied, reproduced, translated or converted to any electronic medium or computer readable form without the prior written permission of Geomar Software Inc.

Geomar Software Inc.
899 Runningbrook Drive
Mississauga, Ontario, Canada L4Y 2S4
Tel: 905 306 9215
Fax: 905 276 8158
e-mail: geomar@geomar.com
web: www.geomar.com

Table of Contents

1. Introduction	1
1.1 About the NAV601 Program.....	1
1.2 Program Requirements	4
1.3 Contents of NAV601 Disk	4
1.4 Installing NAV601	4
1.5 Software Key	5
1.6 Data File Transfer	6
1.7 Running NAV601 Program	6
1.8 NAV601 Program Overview	7
1.9 Surveys Carried Out With GPS Positioning	10
1.10 The NAV601 System Geometry	10
2. Main Menu	13
2.1 Short Description of Main Screen Options.....	13
3. Survey Setup	15
4. System Setup.....	19
5. Logger Setup.....	23
6. GPS Port Setup & Monitoring	27
6.1 GPS Port Setup.....	27
GPS Port Setup Parameters.....	27
GPS Warning Mask Parameters.....	31
6.2 Monitoring GPS Receiver Output	33
7. Map and Profile Display Options.....	39
7.1 Map Display Options.....	39
7.2 Profile Display Options.....	41
8. Logging.....	45
8.1 Logging Screen Layout and Monitoring Mode	46
Navigation Mode	47
Profile Mode	49

8.2	Options Available in Monitoring Mode	51
8.3	Stand By Mode.....	61
8.4	Logging Mode.....	63
8.5	Field Options Available in Stand By Mode.....	65
8.6	Message NO CONNECTION.....	78
Appendix A.	NAV601 Data File Format	81
A.1	Description of NAV601 Data File Format (601).....	81
A.2	Example of NAV601 Data File	85
A.3	Description of GXY Data File	86
Appendix B.	NAV601 and GPS Input	87
B.1	Using the NAV601 with a GPS System	87
B.2	Description of Selected NMEA Data Messages	89
	GGA Data Message	89
	GSA Data Message	90
	POS Data Message	90
	LLK Data Message.....	91
	LLQ Data Message.....	92
	GLL Data Message	92
	GGK Data Message	93
B.3	Configuring GPS Trimble Pathfinder ProXRS System.....	94

Introduction

1

The Geomar TrackMaker601 Data Logging System for the Bartington Grad601 (models Grad601-1 and Grad601-2) consists of a data acquisition program NAV601 and associated PC computer program TrackMaker601. There are several versions of NAV601 programs designed for various field computers. This manual describes the use of the NAV601 program used with the Allegro CX field computer (operating under MS Windows CE.NET V4.20 system), Grad601 magnetometer, and Global Positioning System (GPS).

The associated program TrackMaker601 is used to process data files recorded under the control of program NAV601. Data files created by NAV601 for Allegro CX (Windows CE.NET system) are supported in TrackMaker601 version 1.50 or later. Earlier versions of TrackMaker601 support data files created by NAV601 for DOS only. New version of the program (version 1.50 or later) can process Windows CE based data files as well as DOS files. Main function of this program is to position the magnetic sensors based on the recorded GPS position and the configuration of the system. The TrackMaker601 also allows you to correct the collected GPS positions with post-processed GPS files. In case of grid based surveys (without GPS positioning) the program can export data to a file ASCII format that can be used as an input file in other software that accepts general text format.

1.1 About the NAV601 Program

Program NAV601 acquires and records survey data from the Grad601 unit, under the control of the operator. It also records various field information such as survey line number (line name), starting station, increment, comments, etc. Readings are given in real time in nT. In addition, the program allows you to monitor the instrument output while data are not recorded. The NAV601 also continuously monitors the Allegro battery level, as well as a performance of a connected GPS receiver.

During data collection the program can work in two display modes: navigation and profile mode. While in navigation mode, the main portion of the screen displays all logged positions marked by dots and current position of the system denoted by cross mark based on GPS input. The same part of the field computer display may also be switched to profile mode showing data in the form of profiles. Navigation mode is available only when working GPS is connected to the field computer.

In any display mode readings are additionally displayed in real time as numeric values in nT and ppt as well as in graphic mode, as moving graphic bars. The output of the instrument in one or sensors mode (depending on the instrument settings) is represented by two bars, for Sensor 1 and Sensor 2. This allows for very fast visual information about each sensor output. In addition, the program monitors the instrument output while data are not recorded.

The NAV601 can act as a standalone GPS logger if required. This feature can be useful while mapping topographical features (roads, fences, etc.) that are to be presented together with Grad601 data. These files have extension GXY and they can be used in Geomar data processing software for any other instrument (i.e. TrackMaker38, TrackMaker61, Multi61MK2, etc.).

When program operates in navigation mode the display is not limited to the current set of data. The user may also display positions from previously recorded NAV601 (or GXY) file. This allows for the easy and fast location of the last recorded positions (i.e. from former day), as well as fill any gaps in the survey coverage.

The NAV601 accepts NMEA-0183 compatible data from a GPS receiver directly connected to an Allegro field computer. GPS data which is embedded in the NAV601 data file can be processed later in the Geomar TrackMaker601 program. The connected GPS must be able to stream NMEA-0183 compatible messages. The NAV601 uses one of the following types of NMEA messages: a pair GGA/GSA, GGA, POS, GLL, LLK, LLQ, GLL, and GGK, as well as positions given by Leica Robotics Total Station TPS 1100 and TPS1200, and Trimble RTS. Messages POS, GGK, and pair GGA/GSA are preferred since they contain all necessary information. GPS readings Latitude and Longitude, as well as parameters indicating quality of GPS signal: status of real time differential corrections, number of used satellites, and PDOP parameter, are displayed in real time. If Trimble RTS is employed it must stream two labels: **37** (Northing) and **38** (Easting). Label **39** (Elevation) can be used as an option.

If GPS data are not differentially corrected in real time and post processed GPS data will be used for positioning please log GPS data concurrently in NAV601 and in GPS logger. An option "Position Readings using External GPS file" in TrackMaker601 which uses satellite time recorded in both devices is much more accurate than any method that uses computer clock.

System and survey setup parameters are saved in a file, therefore they can be automatically used during subsequent data collection sessions.

Data file names, which can be set by the program based on the computer clock or they are user specified, have extension names 601. Data files are saved to the folder DATANAV601 by default. Deleting and renaming data files can be accomplished by using Windows CE functions.

Over 1,000,000 Grad601 readings can be collected in the field computer Allegro CX with the memory of 64 Mb. This number has to be lowered for GPS data which depending on the used NMEA message may take approximately from 70 to 180 bytes per one GPS position. More data can be saved by using PC Memory Card (Storage Card option). One EM31 record takes 24 bytes. The NAV601 can process, display, and record close to 10 readings per second, which is the maximum update rate of the Grad601.

The maximum number of 14,400 GPS positions is allowed in one file. This corresponds to 4 hours of continuous data collection if GPS positions are collected every second, or 8 hours if GPS data is taken every 2 seconds. However, it is strongly advised to limit files to for example approximately 1 hour blocks, especially when using high frequency data collection.

Data files are permanently saved every time a Pause button is used (whenever logging mode is changed from Logging to Stand By) during data logging. Therefore it is recommended to use Pause button as often as possible, at any turns between survey lines, breaks, etc.

It is strongly advised that even if your GPS receiver supports faster rates the 1 Hz update for GPS positions is used. NAV601 will work with rates higher than 1 Hz, however operation may not be very smooth when scrolling and rescaling display. The data processing program will interpolate all magnetometer stations between GPS positions in the very similar way as GPS receiver in real time. **When higher than 1 Hz or 2 Hz GPS update rate is used all GPS messages are saved in data files for later processing, however, in real time positions are updated at 1 Hz or 2 Hz (depending on the selection) rate.**

1.2 Program Requirements

To successfully use this software, you will need :

Computer

Field computer Allegro CX

Installed MS ActiveSync software (Version 3.50 or later) in desktop PC, or alternatively PCMCIA memory card to transfer files.

Bartington Grad601-1 or Grad601-2

The instrument with associated cables.

GPS Receiver

The GPS receiver capable of streaming NMEA messages (GGA, POS, GLL, LLQ, LLK, GGK), or alternatively Leica Robotics Total Station TPS1100 or TPS1200, or Trimble Robotic Total Station supporting labels 37 and 38.

1.3 Contents of NAV601 disk

The program NAV601 is stored on TrackMaker601 CD distribution disk. All necessary initial files (with extension names .INI) are created in your computer after the program is run for the first time. Check that the file NAV601.EXE is included on the CD or floppy disk. Check that the file NAV601.EXE is included on the CD disk.

1.4 Installing NAV601

While using the Allegro CX the NAV601.exe file can be transferred from a desktop PC using MS ActiveSync software and USB or serial cable provided by manufacturer. Optionally the program can be transferred to an Allegro using the PC memory card.

It is recommended that the program be placed in non-volatile solid state storage. This memory is represented in the Allegro by the C_Drive icon (Figure 1.1). In the My Computer on the Allegro, double-tap on C_Drive icon, then folder C_Program Files will appear. The NAV601 program can be placed in C_Program Files. Folders for data files should be also created in C_Drive, which is a safe area to store data. The program creates folder DATANAV601 which is the default folder for NAV601 files. The NAV601 data files have extension name 601.

For more information about data storage options, refer to Chapter 3 of the Allegro CX manual.

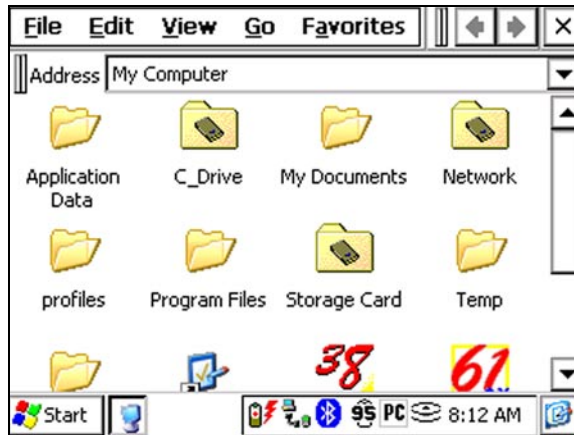

Figure 1.1: The Allegro CX display

1.5 Software Key

The data acquisition program NAV601 is licensed for one field computer. Initialization of the program requires a software key that is based on the Allegro CX serial number. The software key can be given prior to the program installation if the user can provide serial number of the Allegro (it is placed in the Allegro battery compartment or it can be displayed using the Control Panel\System Allegro CX utility). Otherwise, during the first run (after any key is pressed or a command button is tapped) the program will display the Enter Software Key window (Figure 1.2) and the serial number of the AI-



Figure 1.2: Enter Software Key window

legro CX will be displayed at the bottom of the window. Please forward this number to Geomar Software and the Software Key will be provided.

Please enter the software key in the appropriate box in the Enter Software Key window (Figure 1.3) and tap OK or press the Enter key. From now on the program will run without any interruption, unless Allegro C_Drive is completely deleted or formatted. Any future updates of the program will not require entry of the software key.



Figure 1.3: Entering Software Key window

1.6 Data Files Transfer

Data files are saved in the Allegro with extension 601. Transfer of files to desktop PC can be performed with MS ActiveSync or by PC memory card. PC memory card as a way of data transfer is strongly recommended.

NAV601 data files with extension 601 (or GXY if standalone GPS files are created) are binary data files. These files can be loaded and processed in the TrackMaker601 program version 1.50 or later.

1.7 Running NAV601 Program

To run the NAV601 locate program in C_Program Files and double-tap program icon (Figure 1.4). The NAV601 is a Windows CE based, button and dialog driven program designed to be simple to use. Although the program fully supports touchscreen interface, the keyboard entry may be more convenient in most field applications. The NAV601 can

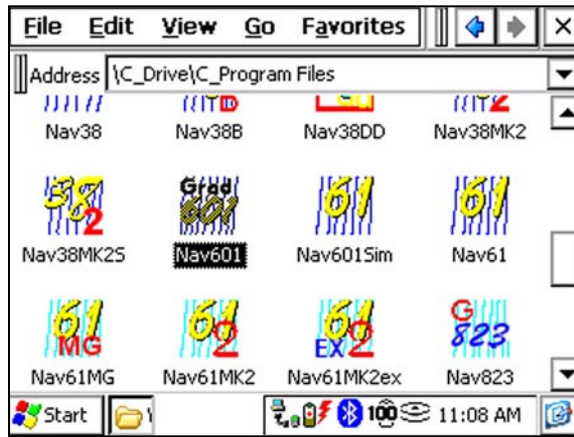

Figure 1.4: Starting the NAV601 program

be almost fully operated from the keyboard when touchscreen functions are disabled by the user. However, while specifying colours and other options in Map and Profile Display Options it is much easier to use touchscreen, and in case of selecting colour from the Windows Color touchscreen is the only option.

Options represented by the command buttons can be accessed by a single tap on the button. Buttons can also be selected from the keyboard by using shortcuts (pressing key corresponding to underline letter in button caption or by selecting button by pressing **TAB** and then execute by pressing **ENTER**. Shortcuts are the fastest way of accessing options represented by buttons.

Most options in the dialog windows are given in the form of text boxes and drop-down boxes which can be accessed using touchscreen or by the keyboard. Each dialog window has a title bar with a caption describing the dialog function and two buttons **OK** and **X (Cancel)**. The **OK** button (or key **ENTER**) confirms dialog selection. Tapping on the **Cancel** button (or pressing **Esc** key) closes the dialog and returns to the initial selection.

1.8 NAV601 Program Overview

The data acquisition program NAV601 was designed with field use in mind. This was the main thought while preparing the program flow. Once all necessary parameters are set in the program they are saved in initial files. Assuming that the survey set up is the same, when the program is started, the instrument and Allegro are turned on, output of the connected Grad601 can be monitored after one key stroke. Obviously any parameters

can be modified any time, however as long as the field procedure remains the same the program needs very minor adjustments, especially when survey is conducted using GPS positioning.

The instruments output is shown in the form of numeric values for Grad601, one or two sensors in nT, as well as plotted in graphic mode. An equalizer type (graphic bars) displays data for Sensor #1 and Sensor #2 as bars in a bar window. Left graphic bar is associated with Sensor #1 values, while the right bar represents Sensor #2 readings. If one sensor is used then only one graphic bar is displayed. In addition moving bars are displayed with different colours that correspond to profile curves colours specified in Profile Display Options dialog. Range of displayed components is common for moving bars window and profile window (in Profile mode). This type of display allows for a legible and very quick estimation of the Grad601 performance. When more detailed monitoring is required each measured value is displayed in numeric form in nT as well. In addition the program can be used in display profile mode and then profiles with last 180 readings are shown in form of profile curves.

When all settings for the system and survey (discussed in later sections) are specified, the user selects Logging option in Main menu of the program. This sets the program in Monitoring mode which allows you to examine the Grad601 sensors outputs and GPS performance. To record data one has to specify the data file name. The program will not allow you to overwrite an existing file. After the data file is created the program will switch to Stand By mode. The Stand By mode allows for continuous data monitoring as well as use available field options. Tapping the Go button (or pressing key G or <ENTER> if it is default button) will change the program to Logging mode and Grad601 and GPS data will be recorded in the data file according to selected mode of operation.

Change of display type between Navigation and Profile modes can be performed by pressing key T (toggle) in the Monitoring or Stand By mode. When working GPS receiver is connected to the field computer then program uses Navigation mode by default. The NAV601 screen in Navigation mode is shown in Figure 1.5. If GPS is not used during the survey the default type of display is Profile mode and Navigation mode is not accessible. Example of the NAV601 screen in Profile mode is given in Figure 1.6. When changing display from Profile to Navigation mode while large number of data is collected, a message Wait is displayed and the program may take several seconds to select the needed coordinates while scanning the entire database of collected positions. There is no such delay during scrolling since the program keeps track of survey path while in navigation mode.

The maximum number of 14,400 GPS positions is allowed in one file. This corresponds to 4 hours of continuous data collection if GPS positions are collected every second, or

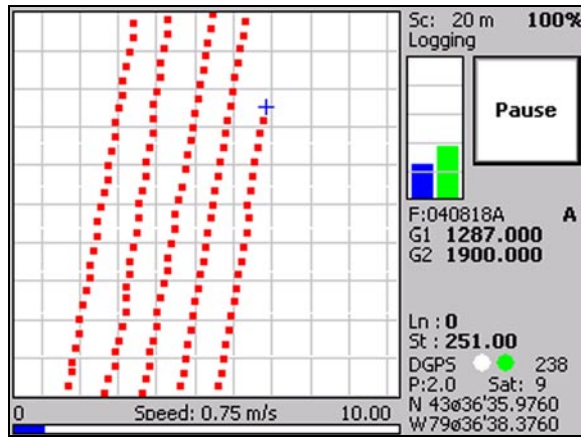

Figure 1.5: The NAV601 in the Navigation mode

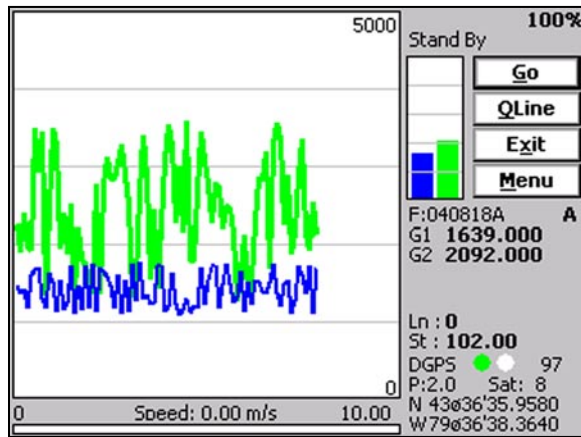

Figure 1.6: The NAV601 in the Profile mode

8 hours if GPS data is taken every 2 seconds. However, it is strongly advised to limit files to for example approximately 1 hour blocks, especially when using high frequency of Grad601 data collection. In case of any possible error in data file it is much easier to correct smaller file. Data files are permanently saved every time **PAUSE** key is used. Therefore, it is good practice to pause data recording at any possible moment, for example at the end of each survey line, at any obstruction, etc.

All data files are created in the program data default directory DATANAV601. This directory contains also initial files. Alternatively data can be recorded in files stored in PC Memory Card (Storage Card option). All data files have extension name 601, and files that contain only GPS positions have extension names GXY.

1.9 Surveys Carried Out With GPS Positioning

Most of the stations positions for surveys positioned with GPS receiver will be calculated based on the GPS antenna position and instant heading of the array. In order to achieve higher quality of data positioning the survey should be carried out along relatively smooth pathways, especially if GPS antenna is located not in the center of the instrument.

When the direction of the survey line is changed it is advised to pause recording of data for the duration of U-turn. Toggling between Stand By mode (pause) and Log mode is relatively easy in the most difficult field conditions, it is done by one key stroke (Pause and Start keys), and it can save time during data processing.

Similar approach applies to situations when the system is stopped. In this case if readings are not paused, the random distribution of small GPS errors will likely result in unreliable locations of calculated sensor positions. If the offset of GPS antenna is used it may appear that the instrument is rotating since GPS errors occur in many directions. Pausing readings while the system is stopped will save time during data processing and will result in better data presentation.

1.10 The NAV601 System Geometry

When a survey is positioned by GPS system the program allows to specify the GPS antenna offset from the Grad601 center. Two parameters, GPS X Offset and GPS Y offset describe location of GPS antenna. This location is represented by the distance which is measured from the center of the magnetometer to the center of the GPS antenna, while facing direction of the movement, see Figure 1.7.

The antenna can be placed anywhere in relation to the instrument center. However to achieve higher accuracy of the calculated positions the GPS antenna must be placed as close to the center of the system as possible.

This option is provided mainly for common situations where the operator carries the instrument on his right side, and GPS antenna (placed in backpack) is located above his

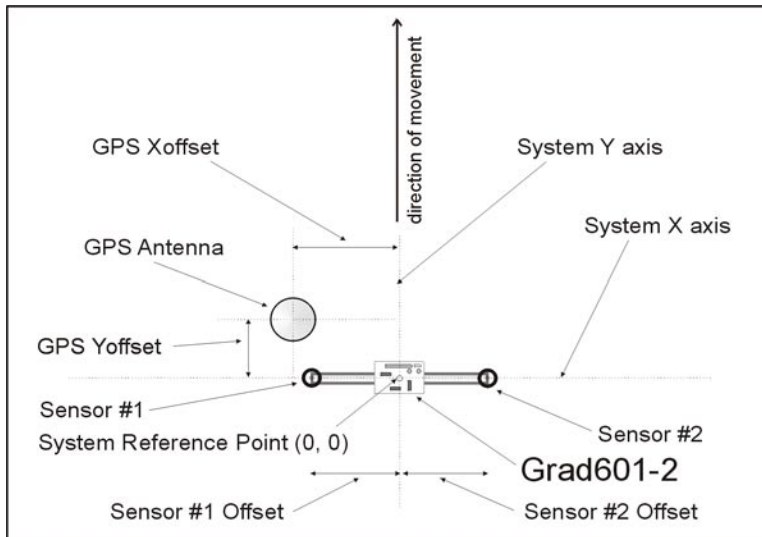

Figure 1.7: The NAV601 system geometry

left shoulder. In this case distance between GPS antenna and the instrument (GPS Xoffset) is negative. During the survey NAV601 display in Navigation mode plots positions of GPS antenna, GPS offsets are applied while processing data in TrackMaker601.

The offset in other direction (GPS Yoffset) can be used if the instrument is towed as long as the GPS antenna is located on the same trailer as the Grad601. If GPS antenna is located i.e. on ATV and the Grad601 is placed on the trailer (there is a point of rotation between them) then the program TrackMaker601 may provide not accurate results. In such case use program GPS-XYZ to calculate layback of the instrument.

In the case where a wrong value was entered in the field, GPS X Offset and GPS Y Offset parameters can be corrected later during data processing in the program TrackMaker601.

Main Screen

2

The Main Screen appears always as the first display after the program is started. It contains the name of the program, its version number, and a list of buttons representing the available options. The NAV601 Main Screen is displayed below in Figure 2.1.

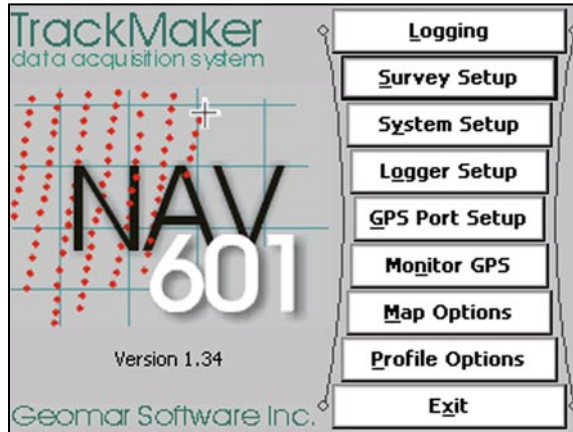

Figure 2.1: NAV601 Main Screen

These options are selected by using tapping buttons, or from keyboard using TAB/ENTER or shortcuts indicated by underline label characters. In case of Main Screen buttons the **Down** and **Up** arrow keys and **<ENTER>** can be used as well. Short description for each of the options follows.

2.1 Short Description of Main Screen Options

Logging

This option allows you to monitor and log the Grad601 output and GPS receiver positions. Logging screen starts always in Monitor mode, and then after a data file is created Logging mode is available. Monitor mode provides initial inspection of the range of the instrument readings at the particular site, and quick inspection of the instrument settings and GPS receiver performance.

Survey Setup

Dialog that is associated with this option is used to set survey line name, line and station increments, and other parameters which are necessary to determine survey settings.

System Setup

This option allows user to enable and disable (if GXY file is to be collected) instrument connection to the logger, select number of probes, and to specify X and Y offsets of GPS antenna.

Logger Setup

The dialog that is associated with this option is used to assign serial port number to the instrument, distance units, speed units, audio click, type of pause key, and selection of data storage.

GPS Port Setup

This option allows you to disable and enable GPS data acquisition. This menu is also used to specify NMEA message that is streamed by GPS receiver, set the serial port number used for GPS input, specify necessary serial port communication settings, and to monitor GPS receiver output.

Monitor GPS

The GPS Monitoring window will be displayed. This option allows you to monitor GPS receiver output, as well as send command to GPS receiver (assuming that GPS device can accept input commands).

Map Options

The dialog that is associated with this option is used to specify plotting parameters for the navigation mode, mainly colours and size of cursor and positions.

Profile Options

This option allows you to select profiles to be displayed, including colour as well as thickness of each profile separately.

Exit

Selecting this option will terminate the program execution.

The Survey Setup dialog, presented below in Figure 3.1, contains several parameters which affect important survey geometry layout: survey line names, line spacing, start station, station increment, etc..

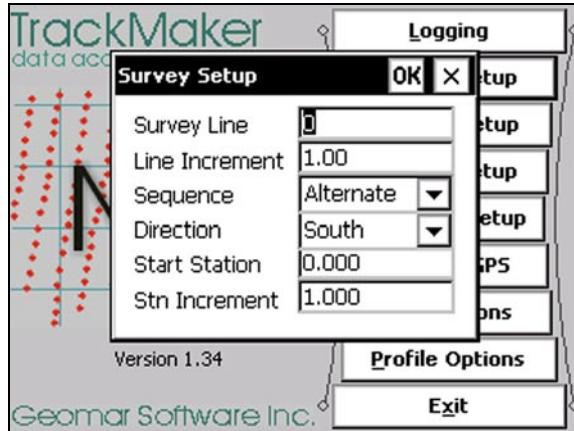

Figure 3.1: Survey Setup dialog in Auto mode configuration

Description of the Survey Setup dialog options and parameters.

Survey Line (survey line name)

Activate text box by tapping or using TAB key and then enter desired name (number) for the survey line.

This is a user's tag number/name for the profile line. The length of the name can not exceed 8 characters.

In case the survey is positioned with GPS system, the Survey Line (and all following parameters described below) can be ignored. The Survey Line, however, can have informative meaning, it can be used to divide or to distinguish certain portions of the survey, without creating new file for each set of data.

During surveys conducted along grid (no GPS positioning) the line name is usually used as a coordinate perpendicular to the survey lines direction. For example, when survey lines are laid out along W-E direction stations describe W-E coordinate, while Line names may describe S-N (vertical on a map) coordinate.

If survey is conducted along grid (no GPS positioning) use negative numbers to

indicate South and West direction. Letters associated with direction (S, N, W, E) can be used, however they must follow numbers and they will be ignored during creating XYZ file in the Geonics DAT31W program (i.e. Line -20S, will be assigned to coordinate -20, South or West depending on the survey layout, while Line 20S will indicate coordinate 20, North or East depending on the survey layout). Letters used in Survey Line name have only informative meaning, they can be used also for naming the same lines, either portions of the same line or if a survey line is repeated (computer program will assign the same coordinate for lines 10, 10A, and so on).

Line Increment

Activate text box by tapping or using TAB key and then enter desired for the survey line increment.

This parameter specifies the distance by which survey lines will be separated. This setting will be used to determine number (name) of the next survey line and will provide automatic survey line name while executing option Quick Line. This parameter can be ignored if survey is positioned with GPS system.

Sequence

Tapping on the down arrow next to the text box opens a drop-down box showing the available settings, or when the keyboard is used activate the text box and then by using up or down arrow keys select one of two available items: Alternate and One Way, Figure 3.2.

Alternate is used when neighboring lines are surveyed in the opposite direction, which is the most common procedure during field surveys.

One Way is used when each survey line is traversed in the same direction.

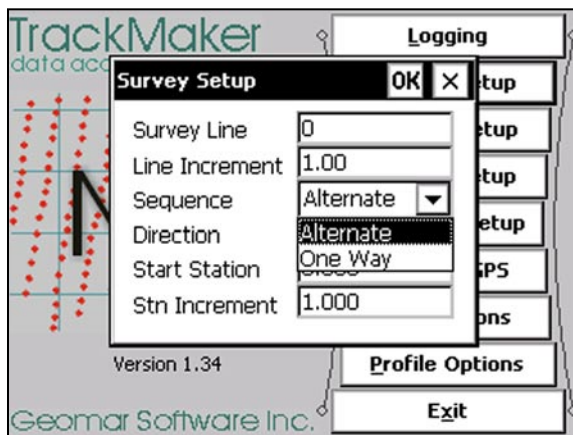

Figure 3.2: Selecting Survey Lines Sequence

The choice of this parameter will affect the default start station, a signature of the station increment, and line direction when parameters for the next survey lines is determined.

This parameter can be ignored if survey is positioned with GPS system.

Direction

Tap on the down arrow next to the text box and a drop-down box will open showing the available options, or when the keyboard is used activate the text box and then by using up or down arrow keys select one of four available settings: East, West, South, and North (Figure 3.3).

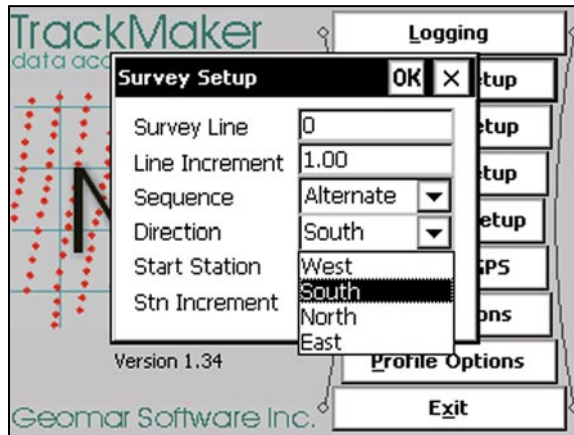

Figure 3.3: Selecting Survey Line Direction

This parameter indicates the heading of the survey line and it can be ignored if survey is positioned with GPS system.

When survey is conducted along a grid, the Direction has only informative meaning. During generating XYZ file, only three parameters: Survey Line Name, Start Station and Station Increment, will be used to determine geometry of the survey layout.

Start Station (start station of a survey line)

Activate text box by tapping or using **TAB** key and then enter the desired value for the start station.

This parameter specifies the starting station number for the selected survey line. This value is used in conjunction with Station Increment to calculate the current station number for display purposes.

If GPS positioning is used, this parameter has only informative meaning. The most convenient is to set Start Station to 0, then the current station will indicate number of stations taken since the start of the data file.

Stn Increment (station or wheel increment)

Activate text box by tapping or using **TAB** key and then enter the desired value for the station increment.

This parameter specifies the station increment for the selected survey line. This value is used in conjunction with Start Station to calculate the current station number for display purposes.

If GPS positioning is used the most convenient is to set the Station Increment equal 1. The station displayed during data recording will indicate number of stations taken since the start of the data file.

After all the parameters in the Survey Setup dialog are updated tap the button **OK** or press **ENTER** key to accept the displayed settings. The program will return to the Main Screen. Updated settings will be written to the initial file and they will be given as default parameters in the subsequent Survey Setup dialog.

To return to original settings (state before this dialog was selected) tap **Cancel (X)** button or press **Esc** key. All parameters will be reset to initial settings and the program will return to the Main Screen.

The System Setup dialog, presented below in Figure 4.1, contains three parameters which enable and disable instrument connection, select number of Grad601 sensors, and specifies GPS antenna offsets in two directions.

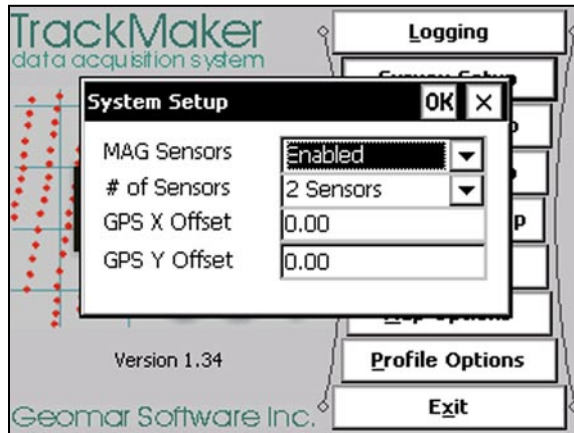

Figure 4.1: System Setup dialog

Description of the System Setup dialog options and parameters.

Mag Sensors (Enable/Disable)

Tap on the down arrow next to the text box opens a drop-down box showing the available settings, or when the keyboard is used activate the text box and then by using up or down arrow keys select one of two available items: Enabled or Disabled.

Select Enable for normal operation when Grad601 readings are to be recorded. When Disabled is selected the program will not record, nor will check for presence of the Grad601 instrument. This feature is used when only GPS positions are to be recorded. In this case created data file will have extension name GXY. These files can be used to survey roads, fences, buildings, or any other topographical features.

Grad601 Type

Tap on the down arrow next to the text box opens a drop-down box showing the available settings, or when the keyboard is used activate the text box and then by using up or down arrow keys select one of two available items: 1 Sensor or 2 Sensors (Figure 4.2).



Figure 4.2: Selecting number of Grad601 sensors

Select item **1 Sensor** for operation when only one probe is used and select item **2 Sensors** if two sensors are connected to the Grad601 magnetometer. This information is written to the data file.

GPS X Offset

GPS Y Offset

Activate GPS X Offset or GPS Y Offset text box by tapping or using TAB key and then enter value for corresponding offset

These two options apply only when a survey is positioned by GPS system. The GPS X and Y offsets describes location of GPS antenna. This location is represented by the distance which is measured from the center of the conductivity meter to the center of the GPS antenna, while facing direction of the movement, see Figure 4.3.

The GPS Antenna offset distances can be given in meters or feet depending on the Distance Unit setting in the Logger Setup menu.

GPS antenna can be placed anywhere in relation to the instrument center. However to achieve higher accuracy of the calculated positions the GPS antenna must be placed as close to the center of the system as possible.

This option is provided mainly for common situations where the operator carries the Grad601 on his right side, and GPS antenna (placed in backpack) is located above his left shoulder. In this case distance between GPS antenna and the instrument (GPS Xoffset) is negative.

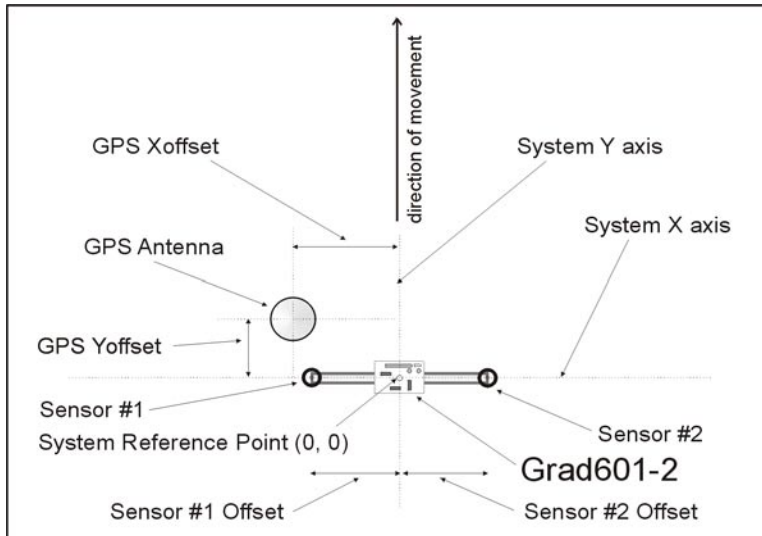

Figure 4.3: Geometry of the instrument and GPS in the field

The offset in other direction (GPS Yoffset) can be used if the instrument is towed as long as the GPS antenna is located on the same trailer as the Grad601. If GPS antenna is located i.e. on ATV and the Grad601 is placed on the trailer (there is a point of rotation between them, see Figure 4.4) then the program

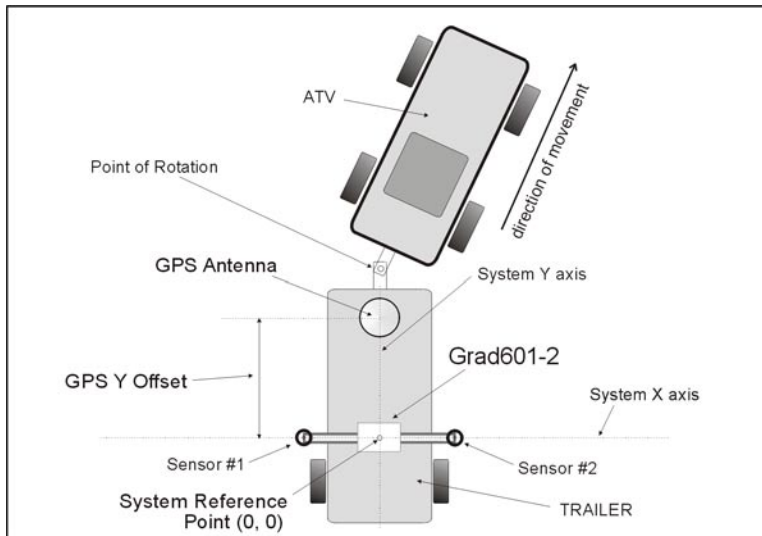

Figure 4.4: Geometry of the Grad601 and GPS antenna during towing

TrackMaker601 may provide not accurate results. In such case use program GPS-XYZ to calculate layback of the instrument.

In the case where a wrong value was entered in the field, GPS X and Y offset parameters can be corrected later during data processing in the program TrackMaker601.

After all the parameters in the System Setup dialog are updated tap the button **OK** or press **ENTER** key to accept the displayed settings. The program will return to the Main Screen. Updated settings will be written to the initial file and they will be given as default parameters in the subsequent Survey Setup dialog.

To return to original settings (state before this dialog was selected) tap **Cancel (X)** button or press **Esc** key. All parameters will be reset to initial settings and the program will return to the Main Screen.

The Logger Setup dialog, presented below in Figure 5.1, contains parameters associated with logger (field computer) settings: assignment of the instrument serial port, units used for stations and GPS antenna offsets, units used for the speed bar, audible signal when reading is taken, choice of Pause key combination, and selection of data files storage.

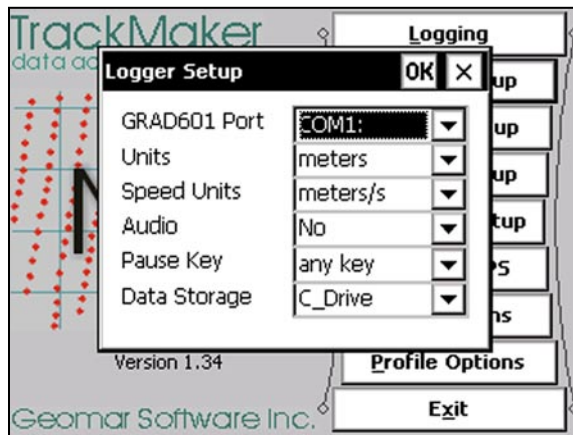

Figure 5.1: Logger Setup dialog

Description of the Logger Setup dialog options and parameters.

Grad601 Port

Tap on the down arrow next to the text box opens a drop-down box showing the available settings, or when the keyboard is used activate the text box and then by using up or down arrow keys select one of the available items: COM 1 to COM12.

This parameter describes how Grad601 is connected to the field computer. The program supports Serial Ports 1 to 12. Any serial port can be assigned to the instrument. Care should be taken the Grad601 instrument is connected to the proper (indicated here) serial port.

Units

Tap on the down arrow next to the text box opens a drop-down box showing the available settings, or when the keyboard is used activate the text box and then by using up or down arrow keys select one of available items.

Two selections are available: **Meters** or **Feet**. These units will be used to display positions and scale map in navigation mode, and to calculate positions for the instrument in program TrackMaker601 if one of the offsets for GPS antenna is different than zero. All parameters that describe geometry of the system should be specified using units selected at this option.

In case wrong selection was entered, units or other parameters can be corrected later in the program TrackMaker601.

Speed Units

Tap on the down arrow next to the text box opens a drop-down box showing the available settings, or when the keyboard is used navigate to the text box by TAB key and then by using up or down arrow keys select one of available options (Figure 5.2).

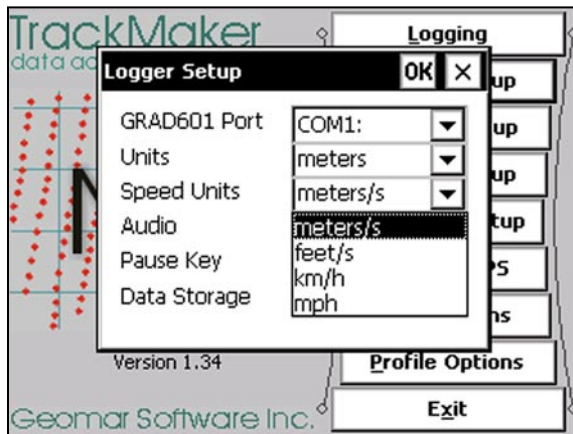

Figure 5.2: Setting Speed Units for Speed Bar

Four selections are available: **meters/s**, **feet/s**, **km/h**, and **mph**. These units will be used to calculate the system speed based on the current and former GPS antenna position. Speed is displayed graphically as a speed bar and in numeric form while logging data during GPS based surveys.

This parameter can be changed later using Menu options during data logging.

Audio

Two selections are available: **Yes** or **No**. The audible click will be generated at each reading when this option is enabled. At fast rate (11 readings/s) the sound may appear not uniform, however this does not affect quality of data acquisition.

Pause key

Tap on the down arrow next to the text box opens a drop-down box showing the available settings, or when the keyboard is used navigate to the text box by TAB key and then by using up or down arrow keys select one of available options (Figure 5.3).

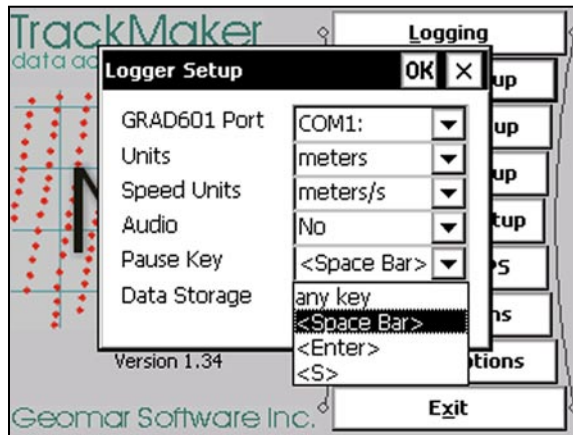

Figure 5.3: Selecting Pause Key in the Logger Setup dialog

Four selections are available: any key, Space Bar, Enter, and P This feature is used to pause data recording during logging session. Default setting any key can be changed to one of the three specific keys for field conditions where a logger key can be accidentally pushed causing unwanted stop of data logging.

Data Storage

A tap on the down arrow next to the text box opens a drop-down box showing the available settings, or when the keyboard is used navigate to the text box by TAB key and then by using up or down arrow keys select one of two available options (Figure 5.4).

Two options are available: C_Drive (default) or Storage_Card. The C_Drive option will create data files in the built in non volatile memory of the Allegro CX field computer. The Storage_Card option is available only when PC memory card is inserted in to Allegro CX PCMCIA slot (located behind the display).

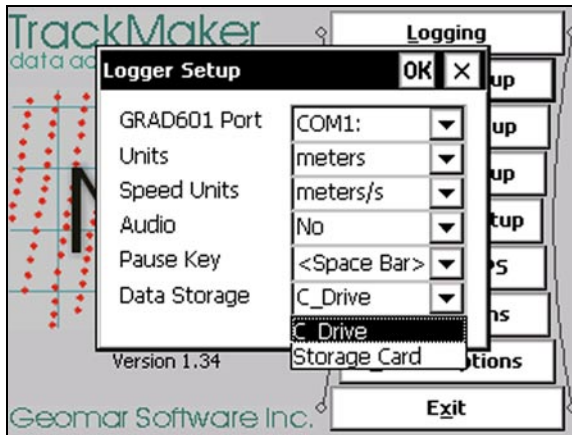

Figure 5.4: Selecting Data Storage in the Logger Setup dialog

After all the parameters in the Logger Setup dialog are updated tap the button **OK** or press **ENTER** key to accept the displayed settings. The program will return to the Main Screen. Updated settings will be written to the initial file and they will be given as default parameters in the subsequent Logger Setup dialog.

To return to original settings (state before this dialog was selected) tap **Cancel (X)** button or press **Esc** key. All parameters will be reset to initial settings and the program will return to the Main Screen.

GPS Port Setup & Monitoring

6

The GPS Port Setup dialog, presented in Figure 6.1, allows for enabling or disabling GPS input, choice of NMEA data string and RTS interface, setting parameters for serial port associated with GPS input, GPS Warning Mask parameters, and maximum display update rate. The GPS Monitoring window allows you to monitor the GPS output in terminal mode as well as to change GPS receiver settings by sending a NMEA command.

6.1 GPS Port Setup Dialog

After the GPS Port Setup button was tapped (or executed from the keyboard) in the Main Screen the GPS Port Setup dialog window is displayed (Figure 6.1).

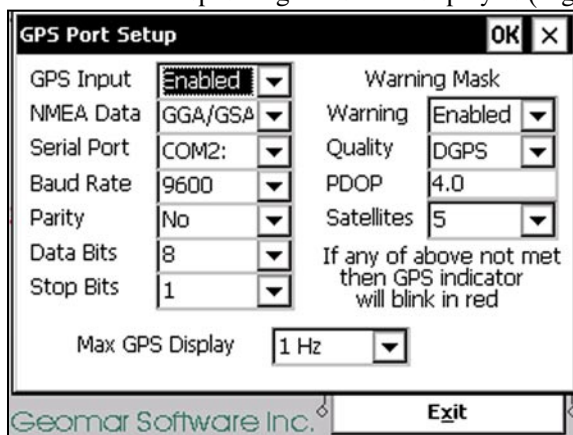

Figure 6.1: The GPS Port Setup dialog window

Description of the GPS Port Setup menu options and parameters.

GPS Port Setup Parameters

GPS Input

Tapping on the down arrow next to the text box opens a drop-down box showing the available settings, or when the keyboard is used activate the text box by navigating with Tab key and then by using Up or Down arrow keys select one of the available items: Enabled and Disabled.

This option allows you to Enable/Disable a serial port for GPS input. When Disabled is chosen logging and monitoring screens will display message “GPS disabled” in place of GPS parameters. Also, when the Disabled item is selected NAV601 will work only in Profile View mode, the Navigation mode will be unavailable.

The GPS Input can be Enabled even if there is no GPS system connected to the Allegro CX. In such case data file will contain proper sequence of Grad601 readings without any GPS input.

NMEA Data

This option allows you to choose NMEA message. The NAV601 can make use of messages: GGA, GGA with associated GSA sentence, POS, GLL, LLK, LLQ, GLL, GGK, and Leica Robotics Total Station TPS1100 and TPS1200, Figure 6.2. Therefore NMEA Data option has seven selections: GGA/GSA, GGA, POS, GLL, LLK, LLQ, GLL, GGK, Leica TPS (covers Leica TPS1100 and TPS1200), and Trimble RTS.

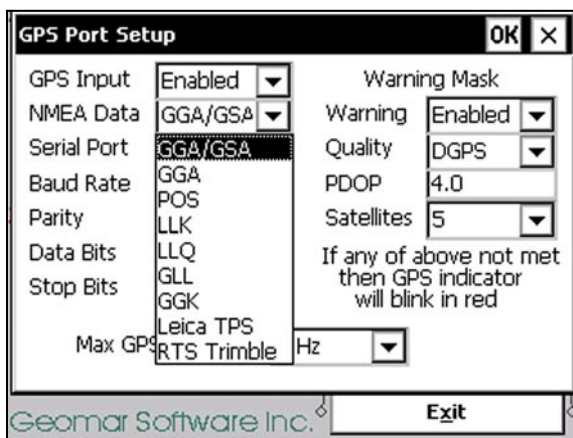

Figure 6.2: Selecting NMEA Data message

Message GGA is supported by almost all GPS receivers. This string is used to record GPS position, while associated message GSA is used to display parameter PDOP which indicates quality of GPS signal. If a GPS receiver supports only GGA string and option GGA/GSA is selected, GPS positions will be recorded using GGA message and PDOP parameter will be displayed as N/A (not available). In such case user should monitor quality of GPS signal using GPS receiver display or can monitor number of available satellites. If GGA option is selected a parameter HDOP will be displayed on the screen.

Messages POS and GGK which are supported by smaller number of manufacturers (however POS is available in all Ashtech receivers and GGK in some a

line of Trimble receivers) are somehow preferable since they contain all necessary information, including the PDOP, in one sentence. If your GPS receiver supports POS or GGK and GGA messages, and PDOP parameter is required, select POS or GGK which provide faster operation for the field computer. Messages LLK and LLQ are used in some Leica GPS systems and provide positions in meters in local coordinate system. When LLK is selected a parameter GDOP will be displayed on the screen. Message LLQ provides precision of positioning in meters and this parameter will be provided on the logger screen. Leica TPS 1100 and TPS 1200 stream pseudo GGA message. Data acquisition is similar to GPS receivers. In most cases the Baud Rate parameter must be selected as 115,200 while working with Leica TPS 1200. Trimble RTS stream separate messages for each parameter. The NAV601 interface requires that Trimble messages 37 (Northing), 38 (Easting), and optionally 39 (Elevation) must be used. Other Trimble labels can be used, however they are not used by the program and it is recommended that required labels (37, 38, and 39) are to be set as starting parameters in the Trimble streamed sequence.

COM Port

The number of serial port that is assigned to the GPS input. Available selections are from **COM1** to **COM 12** with the exception of COM6 (Figure 6.3). The program default is COM2. Communication parameters for the selected serial port can be determined in options described below.

This port must be different than a port specified in the Logger Setup menu for the Grad601 input, otherwise a warning message will be displayed and ports will have to be reassigned.

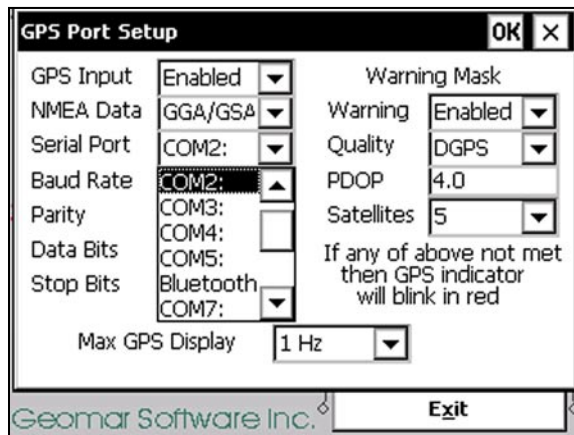

Figure 6.3: Selecting Serial Port for GPS input

Tapping on the down arrow next to the text box labeled Serial Port opens a drop-down box showing the available ports (Figure 6.3), or when the keyboard is used activate the text box by pressing TAB key and then by using up or down arrow keys select one of available items.

Port COM6 is named Bluetooth and it is assigned for Bluetooth communication. This type of connection can be used if GPS receiver is equipped with Bluetooth option. Please refer to GPS receiver manufacturer instructions. Procedure of detecting Bluetooth by the Allegro will be same as described in earlier in section 5.1.

Only one Bluetooth connection can be used by the Allegro operation system, therefore if Bluetooth connection is assigned for Grad601 data acquisition then GPS receiver must use one of physical serial ports.

If Bluetooth communication is selected then all serial communication parameters described below are ignored by the program since they are adjusted automatically by the Allegro operating system.

Baud Rate

Specify Baud Rate for the output port, the entered value should much the Baud Rate of the GPS system, default is 9600.

Parity

Select Parity for the output port, the entered parameter should much the Parity set in the GPS serial port settings, default is N.

Data Bits

Specify Data Bits for the output port, the entered value should much settings in the GPS system, default is 8.

Stop Bits

Specify Stop Bits for the output port, the entered value should much settings in the GPS system, default is 1.

Max GPS Display (maximum update rate for real time display)

Two selections are available: 1 Hz or 2 Hz. This parameters determines frequency of the program display only.

When higher than 1 Hz or 2 Hz GPS rate is used by GPS receiver all GPS positions are saved in data files for later processing, however, in real time positions are updated at 1 Hz or 2 Hz (depending on the selection) rate.

It is strongly advised that even if your GPS receiver supports faster rates the 1 Hz update for GPS positions is used. NAV601 will work with rates higher than 1

Hz, however operation may not be smooth when scrolling and rescaling display while large amount of data is collected. The data processing program will interpolate all Grad601 stations between GPS positions in the very similar way as GPS receiver in real time.

GPS Warning Mask Parameters

Warning

Tapping on the down arrow next to the text box opens a drop-down box showing the available settings, or when the keyboard is used activate the text box by navigating with Tab key and then by using Up or Down arrow keys select one of the available items: Enabled and Disabled.

This option allows you to Enable/Disable a GPS Warning Mask that contains three parameters: Quality Indicator (degree of differential corrections), Dilution Parameter (PDOP or other label depending on the selected NMEA message), and number of available satellites (Figure 6.4).

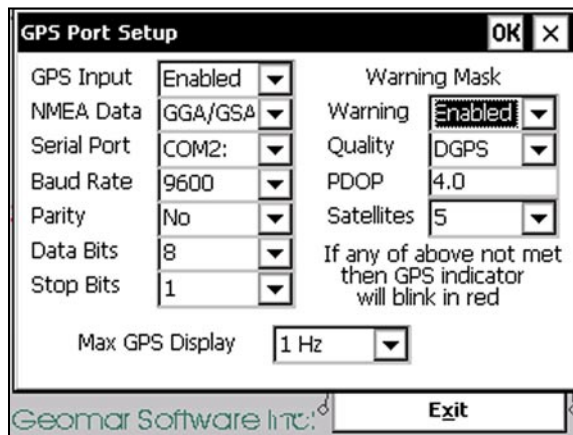

Figure 6.4: GPS Warning Mask section

When Enabled is chosen GPS two circle indicator will be alternating in green and white if conditions for specified parameters setting will be met. When any of the parameters is below set values then GPS indicators will alternate in red and white colours. In case Warning parameter is disabled then GPS indicator will be displayed in green and white colours regardless of GPS signal quality. All GPS data is logged, GPS Warning Mask affects only display.

Quality

This parameter describes Quality Indicator (degree of differential corrections). Tapping on the down arrow next to the text box opens a drop-down box showing the available settings, or when the keyboard is used activate the text box by navigating with Tab key and then by using Up or Down arrow keys select one of the available items: AGPS (Raw), DGPS, RTK3, RTK4, and RTK5.

If Quality Indicator received from GPS receiver will be worse than specified then GPS indicator will alternate in red and white colours.

If any future higher or proprietary Quality Indicator will be send by a GPS receiver it will be treated by the program as RTK5.

PDOP

This parameter can be labeled PDOP, HDOP, DOPG, DOP depending on the selected NMEA message. It can be also named Quality m (accuracy in meters) if LLQ was selected, or it is not available (labeled N/A) when messages GLL or Leica TPS are used.

Activate text box by tapping or using TAB key and then enter the chosen acceptable maximum value of Dilution parameter.

If PDOP (or other similar parameter) is larger than specified value then GPS indicator will alternate in red and white colours.

Satellites

Tapping on the down arrow next to the text box opens a drop-down box showing the available settings, or when the keyboard is used activate the text box by navigating with Tab key and then by using Up or Down arrow keys select one of the available items: 3 to 12 (Figure 6.5).

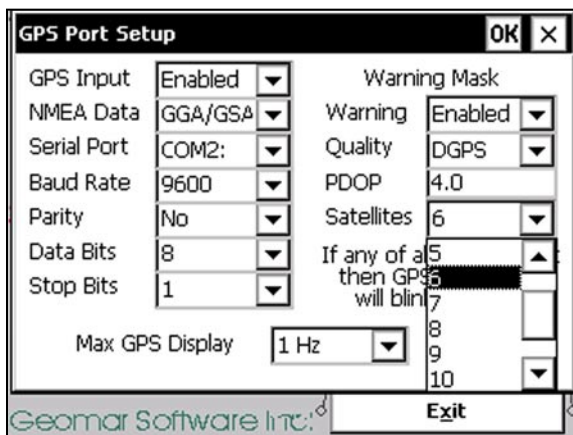

Figure 6.5: Selecting minimum number of satellites

If number of available satellites will be smaller than specified then GPS indicator will alternate in red and white colours.

After all the parameters in the Survey Setup dialog are updated tap the button **OK** or press **ENTER** key to accept the displayed settings. The program will return to the Main Screen. Updated settings will be written to the initial file and they will be given as default parameters in the subsequent Survey Setup dialog.

To return to original settings (state before this dialog was selected) tap **Cancel (X)** button or press **Esc** key. All parameters will be reset to initial settings and the program will return to the Main Screen.

6.2 Monitoring GPS Receiver Output

After the GPS Monitoring button was tapped (or executed from the keyboard) in the Main Screen the GPS Monitoring window appears. The window is divided into three parts. The largest, top portion of the screen displays the GPS receiver output. The middle portion displays recently send NMEA command (or default message) sent to the GPS receiver, and at the bottom, three buttons representing available options: Pause/Go, Send, and Exit. These buttons can be tapped, executed by TAB key and ENTER keys, or by using shortcuts (pressing underlined letter keys). This screen is shown in Figure 6.6. The monitoring mode will work regardless of the GPS Input being Enabled or Disabled in GPS Port Setup dialog.

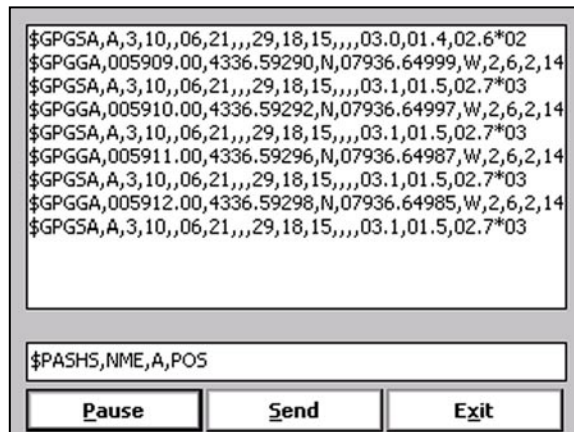

Figure 6.6: Monitoring GPS output in monitoring (terminal) mode

As soon as the NAV601 screen is in terminal mode and the GPS is streaming data, the first portion of each message (limited by the screen width) will appear in the top portion of the display. The display is updated with the frequency the GPS receiver outputs data. This allows you to recognize the GPS update rate and type of messages being sent by the connected GPS. (Example in Figure 6.8 shows output of GPS receiver which sends three NMEA messages GGA, GSA, and POS, updated every second.) In cases where the GPS data is not received by the logger a message NO DATA and current time will appear in the top window of the display, as shown in Figure 6.7.

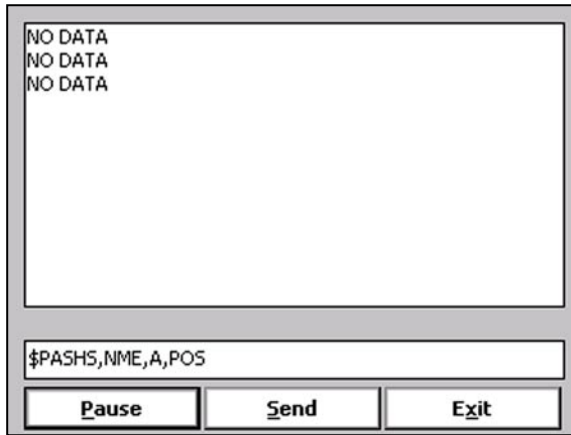

Figure 6.7: GPS Monitoring window when no GPS data is available

The message NO DATA is normally updated with a rate of 6 seconds. This indicates the following:

- serial port number not correctly specified in Set Port for GPS menu,
- the GPS receiver not sending any data,
- not connected or not working GPS receiver.

If the message is updated more often than 6 seconds (i.e. every 1 or 2 seconds) or the display does not show legible characters, it is possible that the GPS is working correctly and is connected to the proper serial port, however communication parameters are not specified correctly. In most cases the Baud Rate or Parity must be adjusted.

The NO DATA message may also appear if the GPS data are received correctly, but the GPS receiver was set to send data with a time interval longer than 6 seconds. In this case the NO DATA message will be displayed in between GPS messages. This indicates that the GPS is working correctly, however the operator should consider adjustment of the GPS receiver output update rate. Most high resolution geophysical surveys require positioning update of 1 or 2 seconds, and a 5 seconds interval can be used only when the survey is carried out at an even pace and along relatively straight survey lines.

The monitoring display can be paused any time by executing the command button **Pause**. At that time scrolling of the GPS output will be stopped, and the same command button will be labeled **Go** (Figure 6.8). The next pressing of this key will activate receiving and display of GPS data.

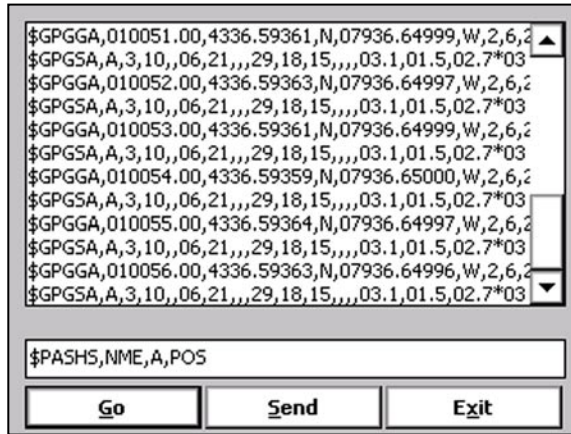

Figure 6.8: Paused monitoring screen

The button labeled **Send** allows you to send a NMEA command to the GPS receiver. It is preferable if the GPS receiver parameters are set using the GPS manufacturer software or controller (GPS logger or panel keys). However, **when the operator is familiar with NMEA protocol and structure of commands for a given GPS system**, this function can be very convenient and useful when the update rate and enabling or disabling messages in the data stream is required.

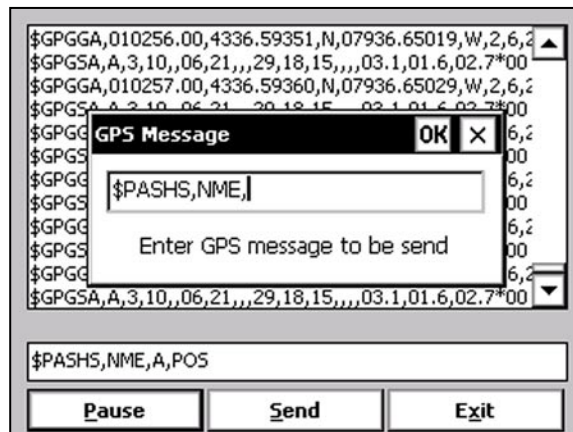

Figure 6.8: GPS Monitoring screen after button *Send* is executed

After the button **Send** is tapped a dialog titled GPS Message is displayed (Figure 6.9) and the beginning of the standard NMEA command, **\$PASHS**, or the last entered command is displayed. After the entire NMEA command is typed in, tap **OK** button or press the key **<ENTER>** to send the command to the GPS receiver. Tapping **Cancel** button or pressing the **<Esc>** key will cancel the command and hide the NMEA Message dialog. An example of a command that will disable the NMEA message **POS** is given in Figure 6.10 (it is assumed that the GPS receiver output serial port is A).

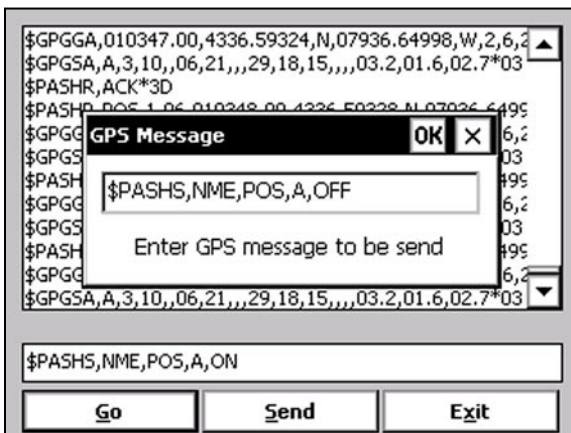

Figure 6.10: Example of the NMEA command entry

After this command is received by the GPS receiver, the confirmation message will be send by the receiver (**\$PASHR, ACK*3D**) and data stream will not contain the message **POS** (**\$PASHR, POS,.....**), as shown in Figure 6.11.

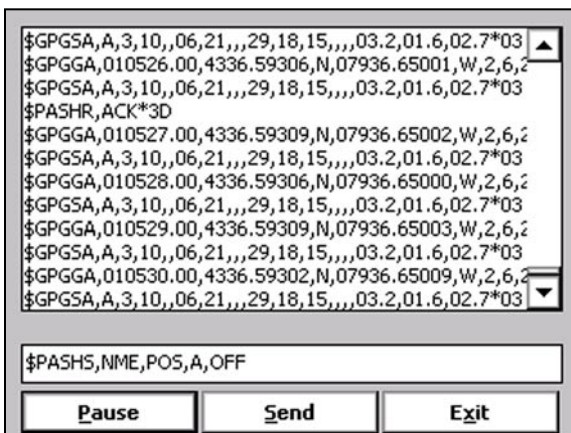

Figure 6.11: GPS Monitoring screen after NMEA command is sent

When the button **Send** is executed next time, the text of the former NMEA command is displayed in NMEA Command dialog. This text can be edited and send to GPS receiver by tapping the button **OK** in dialog window.

Please note, that not every GPS system accepts and uses the same standard set of NMEA commands and messages. In addition, some GPS systems do not accept commands sent by the serial port at all (i.e. Trimble ProXRS or ProXL). The configuration of these type of receivers can be updated only by the controlling device (usually GPS logger, controller, or the receiver panel keys). Please refer to the documentation of a given GPS system before using NMEA Command function.

Map & Profile Display Options

7

The Map Options GPS Port Setup dialog is used to specify plotting parameters for the navigation mode, mainly colours and size of cursor and positions, while the Profile Options dialog allows you to select profiles to be displayed, including colour as well as thickness of each profile separately.

7.1 Map Display Options

After the **Map Options** button was tapped (or executed from the keyboard) in the Main Screen the Map Display Options window appears on the screen (Figure 7.1).

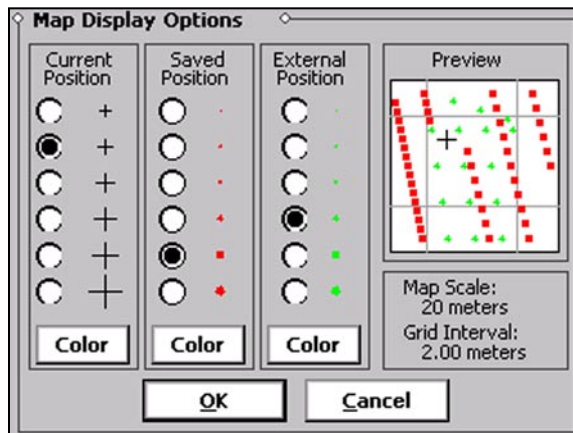

Figure 7.1: The Map Display Options window

This window is divided into 4 sections. The first three sections are used to specify size and colours of plotting parameters, while the fourth section, labeled Preview reflects entered changes in real time.

The first section from the left, labeled Current Position is used to set size and colour of the cursor indicating current position of the GPS antenna. The second section, labeled Saved Position allows you to specify size and colour of a dot marking saved GPS position on the map in Navigation mode. The third section, labeled External Position is very similar to the second section, it allows you to specify size and colour of dot used to

display positions of the External or ASCII files (only one type of file can be displayed at the same time).

The fourth section labeled Preview shows sample map with current settings (specified in the first three sections). It is updated in real time. Below the Preview window, an information about current map scale and map grid line intervals is displayed.

Size of Cursor and Position

Tapping on a radio button in any of three sections will select a size of Cursor or Dot as shown by a graphic image placed next to the radio button. The selection will be immediately reflected in the Preview window, as shown in Figure 7.2 (please compare with Figure 7.1).

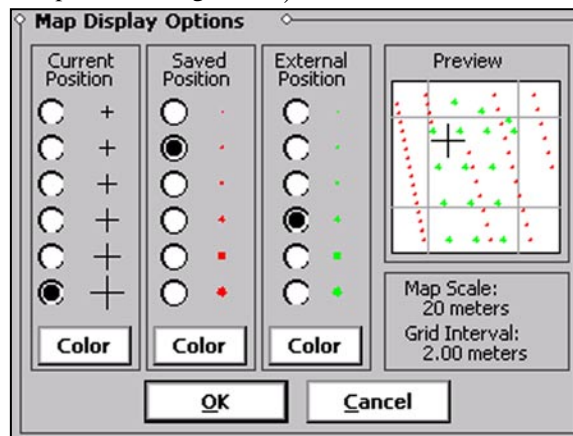

Figure 7.2: *Selecting size of Cursor and Position Dots in Map Display Options window*

Size of Cursor and Position dots shown in the Preview window will be used in Navigation mode during data collection. These parameters can be changed at any time during the survey.

Color

To change colour of the Current Position Cursor or Position dot click on the corresponding button labeled Color. The Color dialog will appear (Figure 7.3). Select desired colour by clicking on a colour box (the selected colour box will be highlighted). Other colours can be specified by clicking on the **Custom** button. The selected color will be used to plot corresponding parameter. Click on the button **OK** or press **ENTER** key (if highlighted) to accept the highlighted colour. The Color dialog will disappear and the colour of the selected parameter (Cursor or Position) will be updated in the Preview window. To cancel colour selection click on the **Cancel** (or X button) button or press **Esc** key.

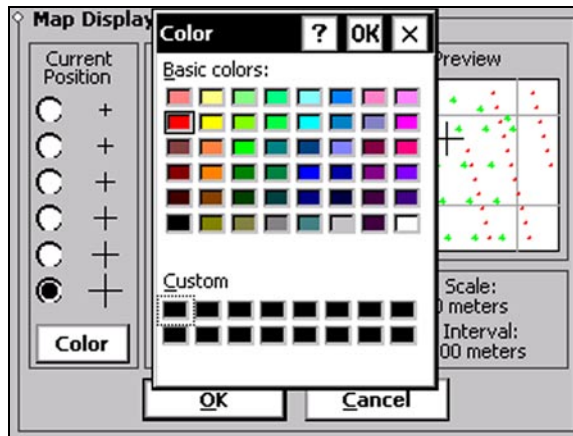

Figure 7.3: *Selecting colour in Map Display Options window*

Selected colours of Cursor and Position dots shown in the Preview window will be used in Navigation mode during data collection. Colour for each parameter can be changed later at any time during the survey.

After all the parameters in the Map Display Options window are updated tap the button **OK** or press **ENTER** key (if the button is highlighted) to accept the displayed settings. The program will return to the Main Screen. Updated settings will be written to the initial file and they will be given as default parameters in the subsequent Map Display Options windows.

To return to original settings (state before this window was displayed) tap **Cancel** button or press **Esc** key. All parameters will be reset to initial settings and the program will return to the Main Screen.

7.2 Profile Display Options

After the **Profile Options** button was tapped (or executed from the keyboard) in the Main Screen the Profile Display Options window appears on the screen. This window is used to specify plotting parameters for the program Profile View mode. The window allows you to enable and disable the display of each profile (one for each Grad601 sensor), to specify color and thickness of line representing each profile, and to select grid lines for selected scale. The Profile Display Options window is presented in Figure 7.4.

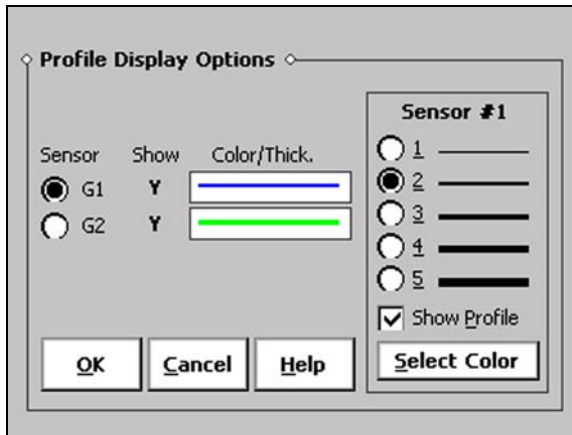

Figure 7.4: Profile Display Options window when the Sensor 1 (G1) profile is selected

To set parameters for any profile click on the radio button labeled **G1** and/or **G2**. These labels correspond to two possible combinations of two sensors readings. The state of radio buttons (on the left) is reflected by a section located in the right portion of the Profile Display Options. This section labeled according to the left portion of the buttons selection (see Figures 7.4 and 7.5) allows you to select profile line thickness and colour.

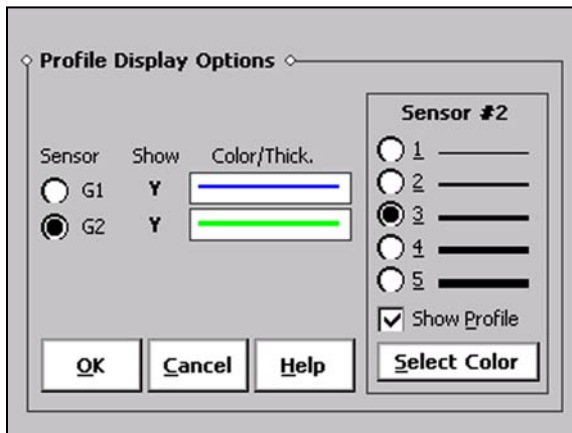

Figure 7.5: Profile Display Options window when Sensor 2 (G2) profile is selected

Select Profile to be Plotted

A check box button labeled **Show Profile** is used to select or deselect particular profile. When check box is marked then a symbol Y is placed in column labeled Show, otherwise this symbol disappears (see Figure 7.6 for configuration G2).

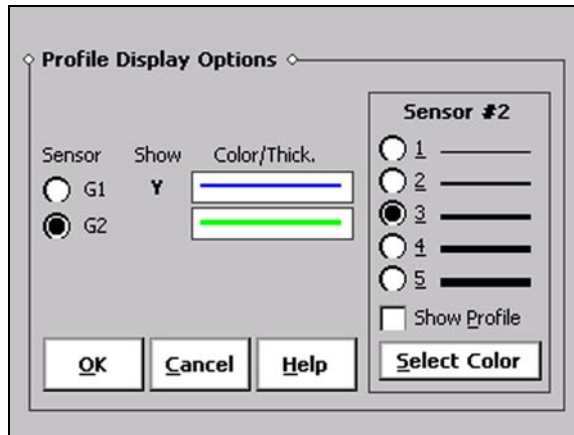

Figure 7.6: Profile Display Options window with deselected Sensor 2 (G2) profile

Select Thickness

To change thickness of the selected profile click on one of radio buttons labeled from 1 to 5 with at graphic samples of thickness. An example of the profile in one of white windows labeled Color/Thick. will be updated in real time.

Select Color

To change color of the line click on the button labeled **Select Color**, a Color dialog (see Figure 7.3) will appear. Select desired colour by clicking on a colour box (the selected colour box will be highlighted). Other colours can be specified by clicking on the **Custom** button. The selected color will be used to plot corresponding parameter.

Click on the button **OK** or press **ENTER** key (if highlighted) to accept the highlighted colour. The Color dialog will disappear and the colour of the selected parameter (Cursor or Position) will be updated in the Preview window. To cancel colour selection click on the **Cancel** (or X button) button or press **Esc** key. After color is selected a sample of profile (in column labeled Color/Thick.) will be updated immediately.

After all the parameters in the Profile Display Options window are updated tap button **OK** or press **ENTER** key to accept the displayed settings. The program will return to the Main Screen. Updated settings will be written to the initial file and they will be given as default parameters in the subsequent Profile Display Options.

To return to original settings (state before this dialog was selected) tap **Cancel** button or press **Esc** key. All parameters will be reset to initial settings and the window will disappear.

After the **Logging** button (in Main Screen) is tapped or executed by the keyboard, the program enters logging session and starts to read data from the connected Grad601 and GPS receiver. Logging session contains three modes: Monitoring, Stand By and Log. Further each of these modes can use Navigation or Profile mode of the display. If the GPS Input is disabled then only the Profile mode is available. When the program starts in Navigation mode and less than 14,400 positions is available the message with info regarding maximum of number of GPS positions in the file is displayed (Figure 8.1). In most cases maximum number of positions (14,400) can be accommodated and the message will not appear. However, this number depends on the computer memory and may be smaller if used with other than Allegro CX field computer.

Program starts Logging session always in Monitoring mode and in Navigation display mode if GPS Input is enabled (Figure 8.1). In this mode Grad601 and GPS readings can be quickly examined, and instrument settings can be adjusted. Stand By mode is similar to Monitoring mode, however different options are available. Recording of Grad601 and GPS data is allowed only in Logging mode, which is accessible from Stand By mode. In general after the data file is created in the Monitoring mode, two modes Stand By and Logging are toggled by Start and Pause keys. In Stand By mode instrument outputs can be monitored and some survey parameters can be changed, and Logging mode is used only to record data.

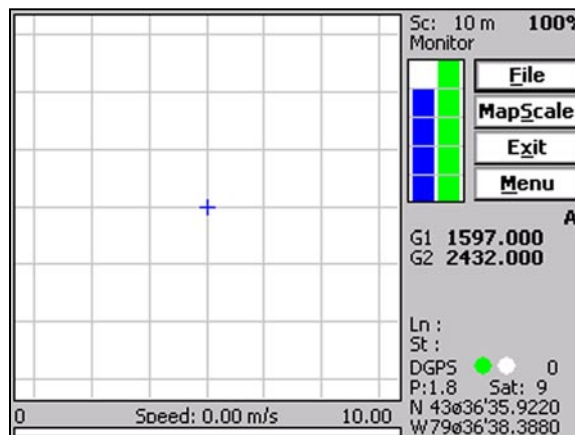

Figure 8.1: Initial NAV601 Monitoring screen in Navigation mode

It is assumed that all settings, especially assignment of serial ports, are correctly specified and instrument is turned ON prior to using this option. In case the instrument is OFF or it is not connected to the field computer the message shown in Figure 8.2 will appear. This message will not appear if option Grad601 in System Setup dialog is Disabled.

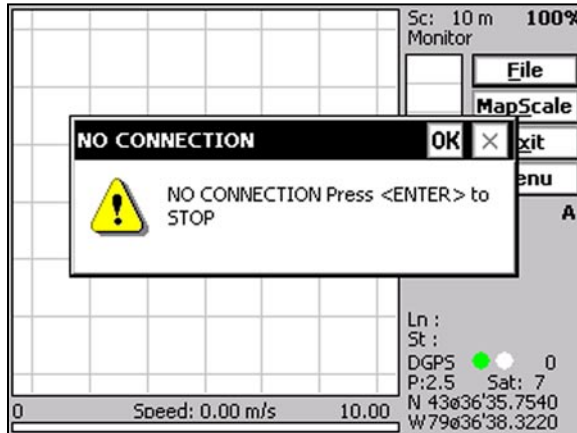

Figure 8.2: No Connection message in Navigation mode

Check program settings (Logger Setup), connection, or turn the instrument ON and select the Logging option again.

Assuming that instruments work properly the program will initialize connection with Grad601 and a screen in Monitoring mode will be displayed.

8.1 Logging Screen Layout in Monitoring Mode

The NAV601 Monitor mode allows initial inspection of the range of the instrument readings at the particular site, monitoring the instrument performance, number of sensors, monitoring number of available GPS satellites, GPS differential corrections, PDOP parameter status, and Latitude and Longitude coordinates. Speed bar located at the bottom of the screen shows current instrument speed (over the ground) which is calculated from GPS data.

The Grad601 readings in Monitoring and Stand By modes are updated approximately 10 times per second during monitoring session. GPS positions are updated at a rate specified in GPS receiver, usually 1 second interval.

Navigation Mode

When the GPS Input is Enabled in GPS Port Setup menu then the program displays the screen in Navigation mode by default. The NAV601 Logging screen in Monitoring mode and Navigation display mode is shown below (Figure 8.3).

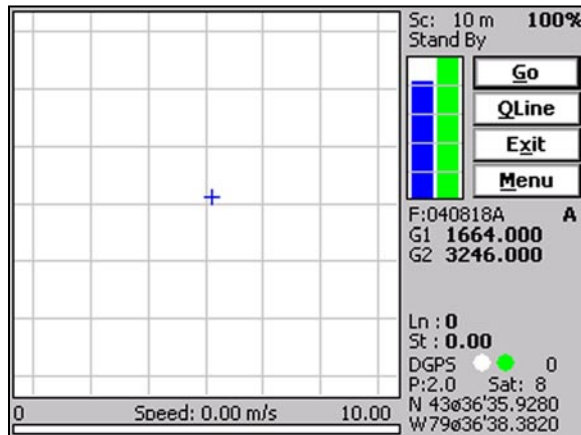

Figure 8.3: Logging screen in Monitoring (Navigation) mode

The left portion of the screen is occupied by the square plot area, a map, which presents current location of the system (based on GPS antenna position) in graphic form. This plot area will also display all recorded positions during data recording. The side of the square corresponds to scale which is displayed at the top line of the screen, right to the plot area. The scale can be given in meters or feet depending on Units selection in the Logger Setup menu. Figure 8.3 shows map area that represents square 10 x 10 m. A cross mark indicating current position of the GPS antenna (usually indicating position of the instrument) is always placed in the center of the map when logging session starts. After the operator will start moving the cross mark will move accordingly, however traces will not be plotted. Points indicating GPS stations are plotted only in Log mode when Grad601 and GPS data are recorded. The North points to the top of the screen.

The Monitoring screen will display GPS related information in four bottom lines of the right portion of the display.

A label **DGPS** (Differential Global Positioning System) indicates that GPS readings are differentially corrected in real time, while label **AGPS** (Autonomous Global Positioning System) indicates lack of differential correction. Three other labels can be displayed: **RTK3** (Real Time Kinematic) when Quality Parameter is 3, and **RTK4** and **RTK5** for Quality parameters equal 4 or 5. On the right side of **DGPS**, **AGPS**, or **RTK** label two

small circles are displayed. A colour of each circle should alternate between white and green with the frequency of GPS update rate (usually 1 second intervals), Figures 8.1 and 8.3. When GPS signal is below parameters set as GPS Warning Mask the circles colour changes from green to red. If circles are displayed in one colour for long periods of time it means that the GPS system is not working or that it is not connected to the field computer.

The next label **P** with a value varying between 0 and 99.9 represents an index called Position Dilution of Precision (**PDOP**). PDOP is given when NMEA data messages GGA/GSA, GGK or POS were selected. If only message GGA is available, then index HDOP (labeled **H**) will be displayed, and when LLK message was selected parameter GDOP (labeled **G**) is displayed. The LLQ message will provide precision of positioning in meters and it is labeled by **X**. Refer to section 6 (Set Port for GPS), Appendix A, and to GPS manuals for more information about GPS parameters.

The label **Sat** and following number shows number of currently tracked satellites. Latitude (N) and Longitude (W) are displayed in two bottom lines. These values are given in degrees, minutes, and seconds with four decimal places.

The remaining portion of the monitoring screen display available options and parameters associated with the Grad601 output. The Grad601 output is represented by two moving vertical bars. The left grid displays bars associated with Sensor 1 readings, while the right bar represents Sensor 2 amplitude. Range of readings displayed in this grid can be adjusted (option Profile Scale), however bar window is labeled. The scale for graphic bars is divided by four or five dotted grid lines. In the case where the amplitude scale starts with a negative value, then the grid line corresponding to zero is always plotted as a solid line. This type of graphic presentation allows the operator for very easy and quick monitoring the response of all connected instruments.

Readings for both Grad601 sensors are shown in numeric form below the grid area. Data for Sensor 1 and Sensor 2 are labeled **G1** and **G2** correspondingly. Due to the small screen of the field computer, readings are not labeled and they are given in nT.

Several other parameters are shown on the right side of map plot area. Label **Monitor** indicates Monitoring mode. Labels **Stand By** and **Logging** will be displayed for Stand By and Log modes respectively. Labels **Ln** (line name), **St** (current station) and corresponding parameters are not used in Monitoring mode.

Four command buttons (on the right side of the grid containing moving bars) provide access to options available in Monitoring mode. These options are described below in the section 8.2.

Profile Mode

When the GPS Input is Disabled in GPS Port Setup dialog then the program displays the screen in Profile mode. The same mode is displayed when GPS was Enabled and the operator used Toggle option to display program in Profile mode. The NAV601 Logging screen in Monitoring mode and Profile display mode is shown below (Figure 8.4).

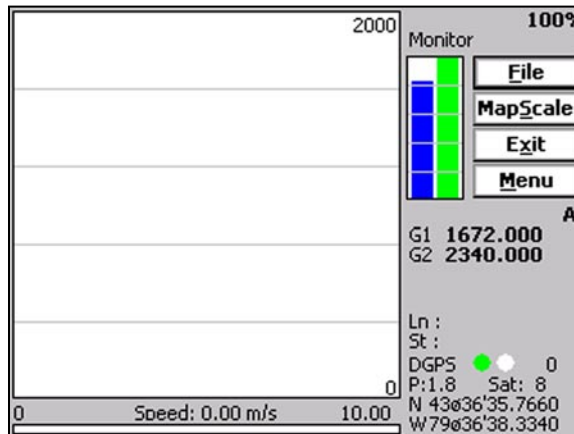

Figure 8.4: Logging screen in Monitoring (Profile) mode

The left portion of the screen is occupied by the square plot area that will contain profile curves for each recorded and selected (in Profile Options window) Grad601 data type in graphic form. Scale is labeled at the top and bottom on the right side of the plot area in nT.

The Grad601 output is also represented by two moving vertical bars. The left bar displays values associated with Sensor 1 readings, while the right bar represents Sensor 2 amplitude. Range of readings displayed in this window can be adjusted (option Profile Scale), however it is not labeled. The scale for graphic bars is divided by four or five dotted grid lines. In the case where the amplitude scale starts with a negative value, then the grid line corresponding to zero is always plotted as a solid line. This type of graphic presentation allows the operator for very easy and quick monitoring the response of all connected sensors.

Readings for each sensor are shown in numeric form below the grid area. Data for Sensor 1 and Sensor 2 are labeled **G1** and **G2** correspondingly. Due to the small screen of the field computer, readings are not labeled, they are given in nT.

The grid with moving vertical bars and data displayed in numeric form are updated approximately 10 times per second in Monitoring and Stand By modes. Profiles are plotted only in Logging mode when readings are actually recorded in data file.

Several other parameters are shown on the right side of map plot area. Label **Monitoring** indicates Monitoring mode. Labels **Stand By** and **Logging** will be displayed for Stand By and Log modes respectively. Labels **Ln** (line name), **St** (current station) and corresponding parameters are not used in Monitoring mode.

If a working GPS system is connected to the field computer and GPS was **Enabled** in the GPS Input Setup menu the Monitoring screen will display GPS related information in three lines at the bottom of the display. Latitude (N) and Longitude (W) are displayed in two lines. These values are given in degrees, minutes, and seconds with four decimal places. In the line above Latitude the parameters describing quality of GPS positions are displayed. The label **S** and following number shows number of currently tracked satellites. A label **D** (Differential Global Positioning System) indicates that GPS readings are differentially corrected in real time, while label **A** (Autonomous Global Positioning System) indicates lack of differential correction. On the right side of **D** or **A** label small circle is displayed. This circle blinks (alternates colour) white and green with the frequency of GPS update rate (usually 1 second intervals). If the circle displays one colour for long periods of time it means that the GPS system is not working or that it is not connected to the field computer. The next label **P** with a value varying between 0 and 99.9 represents an index called Position Dilution of Precision (**PDOP**). PDOP is given when NMEA data messages GGA/GSA, GSK or POS were selected. If only message GGA is available, then index HDOP (labeled **H**) will be displayed, and when LLK message was selected parameter GDOP (labeled **G**) is displayed. The LLQ message will provide precision of positioning in meters and it is labeled by **X**. Refer to section 6 (GPS Port Setup), Appendix B, and to GPS manuals for more information about GPS parameters.

When GPS was Disabled in the GPS Port Setup dialog then instead of GPS information a label GPS Disabled is displayed. In such case the Navigation mode is not available and the program will work only in Profile mode.

Four command buttons (on the right side of the grid containing moving bars) provide access to options available in Monitoring mode. These options are described below in the section 8.2.

8.2 Options Available in Monitoring Mode

Several options are available while the Logging window is in the Monitoring mode. Four frequently used options can be accessed directly from command buttons and others can be used from pop up menu activated by the button **Menu** (displayed in Figure 9.5). Command buttons can be used by tapping on the desired button, or from the keyboard by pressing one of the shortcut keys (underlined characters on button labels) or by navigating using **TAB** key (sets button as a default button - default button is highlighted) and pressing **ENTER** key.

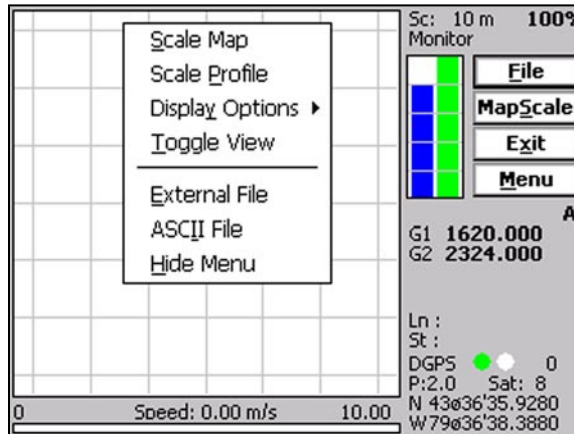

Figure 8.5: Logging screen in Monitoring mode with displayed pop up menu

Options listed in the menu can be accessed directly (without displaying pop up menu from Menu button) by using keyboard shortcuts, i.e. pressing key **P** will display Profile Scale dialog. While menu is displayed options can be selected by tapping on the appropriate item, or from the keyboard by pressing the shortcut keys or by navigating using **Up** and **Down** arrow keys and executing by **ENTER**.

File (create data file)

After a data file is created the program will switch to Stand By mode automatically.

The data file can be created in the given default directory (DATANAV601) or in any other directory in the Allegro CX as long as it is located in C_Drive or in user supplied Storage_Card (see System Setup dialog). The C_Drive represents save, non volatile memory.

The name of the file is given by the field computer clock and it consists of month (2 digits), day (2 digits), hour (2 digits), and one alphabetic character A,

B, C, etc. (If all letters during one hour are used the name can be overwritten by the operator). The Create Data File dialog is presented in Figure 8.6.

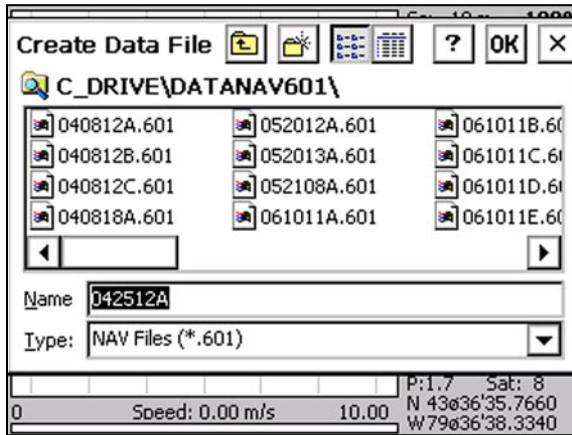

Figure 8.6: Create Data File dialog

The file name can be specified in the Create Data File dialog using the Windows standard interface procedure. The Grad601 data files cannot be appended. Each data file in the field computer (raw data file) has an extension name 601 and it is created in the directory specified in Create Data File dialog. The 601 files are created in the binary format.

After the file is specified tap the button **OK** or press **ENTER** key to accept and create data file. The program will switch Monitor mode to Stand By mode and the data file will be displayed on the screen.

To cancel selection and return to Monitoring mode tap the **Cancel (X)** button or press **Esc** key.

Each data file in the field computer created by NAV601 has an extension name 601 (unless it is GXY file created when Grad601 was Disabled in the System Setup window). The 601 data files are in a binary format. Their content can be viewed when loaded to TrackMaker601 program. These files can be also converted to ASCII format

When a data file is created the program will switch to Stand By mode automatically (see section 8.3).

Map Scale

This option is available by tapping on the command button labeled **Map Scale**, from pop up menu (accessible from **Menu** button), or directly from keyboard by using shortcut key **S**. The Enter Map Scale dialog will appear on the screen, Figure 8.7.

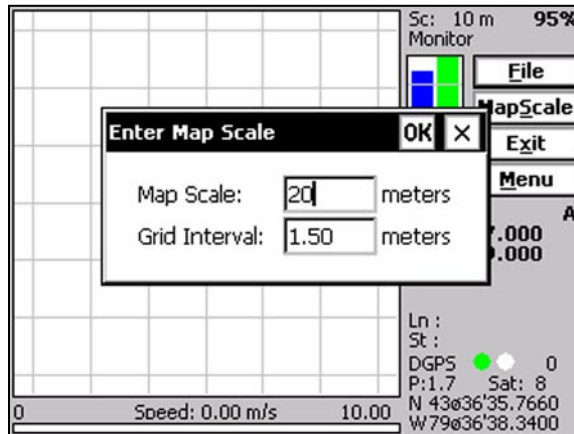

Figure 8.7: Enter Map Scale dialog

This dialog allows the operator to enter new scale for the map displayed by the plot area. Value is entered either in meters or feet according to selected units in Logger Setup dialog and it represents side of the square map. Only positive integer values ranging between 1 and 9999 are allowed by the program.

The second parameter in the Enter Map Scale is Grid Interval. These are grey grid lines in Navigation mode which may be helpful in estimation of distance on the map displayed in Navigation mode. Maximum number of grid lines is 20 in one direction, therefore for the maps scale 20 m the minimum grid interval is 1 meter. The program will recalculate grid interval in case too large scale will be entered. Setting Grid Interval to zero will not plot any grid lines on the screen.

After the file is specified tap the button **OK** or press **ENTER** key to accept and create data file. The program will switch Monitor mode to Stand By mode and the data file will be displayed on the screen.

To cancel selection and return to Monitoring mode tap the **Cancel (X)** button or press **Esc** key.

Profile Scale

This option is available from pop up menu (accessible by tapping the **Menu** button), or directly from keyboard by using shortcut key **P**. The Enter Profile/Bar Scale dialog will appear on the screen, Figure 8.8.

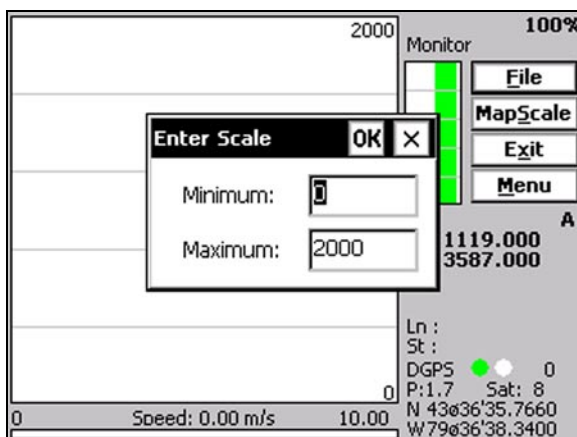

Figure 8.8: Enter Profile and Bar Scale dialog

Minimum and maximum values can be specified for the plot range in the grid window containing two moving bars as well as for the profile plot display if the Monitoring screen is in Profile display mode. Therefore range of displayed data is the same for the profile display area and for the grid area with vertical bars. However only profile plot area is labeled at its right side (Figure 8.9).

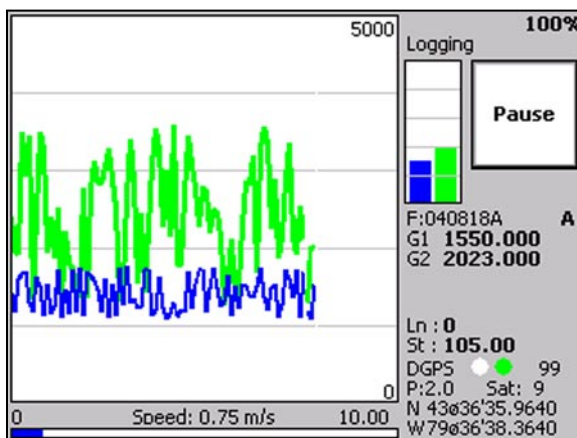

Figure 8.9: NAV601 display in Profile mode

After minimum and maximum values for each component are specified tap the button **OK** or press **ENTER** key to accept new values and the display will be redrawn. To cancel selection tap the **Cancel (X)** button or press **Esc** key.

Display Options

(Map Options, Profile Options, and Speed Bar)

The Display Options item has three submenus. These are Map, Profile, and Speed Bar, Figure 8.10. Items Map and Profiles are identical to Map Display Options and Profile Display Options described in detail in Chapter 7. They can be accessed from pop up menu or directly by the keyboard pressing **A** or **R** keys.

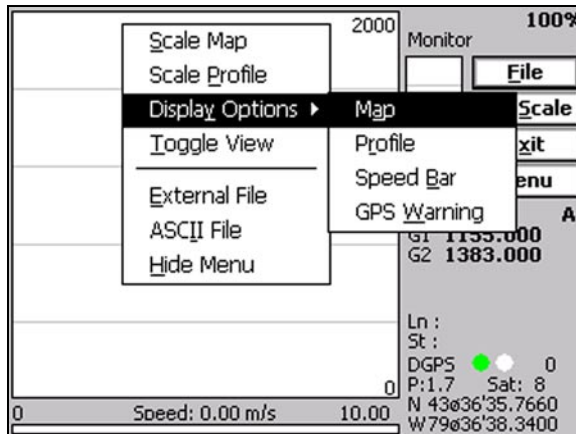

Figure 8.10: Extended pop up menu

Scale Speed Bar

(adjust scale for speed bar)

The minimum value for the Speed Bar is preset to 0, therefore this scale requires only entry for the maximum speed. The Speed Bar Scale is given in Figure 9.10.

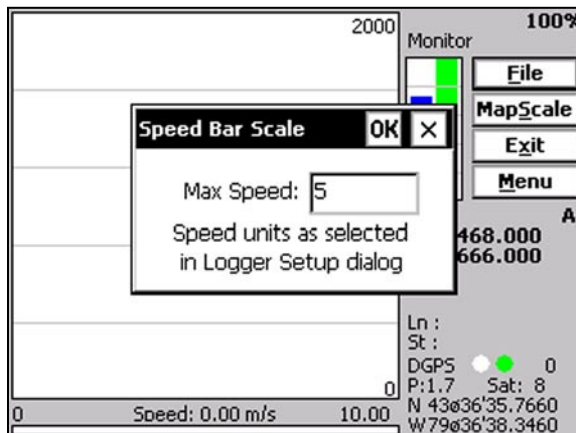

Figure 8.11: Speed Bar Scale dialog

The entered scale applies only to graphic representation of the speed (graphic bar), speed in numeric form is always displayed above the bar,

even if the real value exceeded maximum specified for the speed bar. After the maximum value for the speed bar is specified tap the button **OK** or press **ENTER** key to accept new values and the display will be re-drawn. To cancel selection tap the **Cancel (X)** button or press **Esc** key.

Toggle View (toggle between Navigation and Profile modes)

Selecting this item from pop up menu or simply pressing the key **T** will switch Monitoring or Stand By screens between Profile and Navigation modes. Changing the display from Profile to Navigation mode may take several seconds (depending on number of positions displayed and map scale). The program will display message **WAIT** till all positions are plotted in current map area and it will beep at the end of this process.

External File (External TrackMaker Data or GXY File entry)

This option allows to display GPS positions from formerly acquired data file. Files created with NAV601, as well as data or GXY files created with any other Geomar data acquisition programs (i.e. NAV61, NAV38, ML61, etc.) can be entered. This option is useful in cases where the operator wants to review the coverage of the surveyed area, to find the last station surveyed in a previous day, cover an area already surveyed with different instrument, or simply to increase density of stations in previously surveyed area.

After the item is selected from pop up menu or from the keyboard (by pressing the **E** key) the standard window dialog Open File is displayed (Figure 8.12). File name must include extension file name (i.e. H31, N61, GXY, etc.). Specify file name using the Windows standard interface procedure.

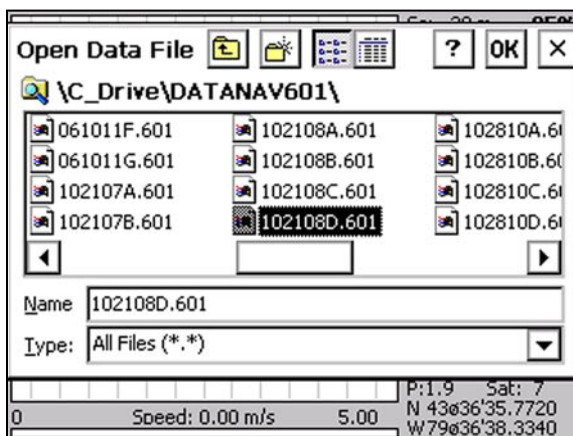

Figure 8.12: Open External File dialog

After the file is selected a message with number of positions in the file will be displayed. At the same time depending on the available memory the program

will provide a number of positions that will be displayed (Figure 8.13). If all positions can not be displayed, then the program will plot every second, or third (and so on) GPS position, however the first and last stations recorded in the file will be always plotted.

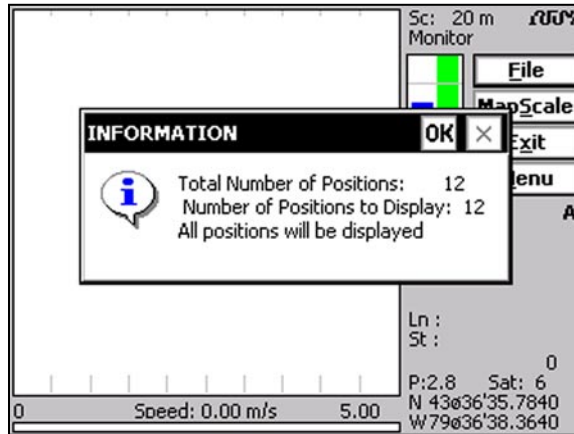

Figure 8.13: Number of Positions to be displayed

After confirming this message by tapping the button **OK** or pressing **ENTER** key the program starts to display positions recorded in the entered file. This operation can take several seconds depending on the file size and scale of the map area. Therefore message labeled **WAIT** located at the right side of plot area will remain till all positions are displayed. In addition a beep will signal the end of plotting. Layout of GPS stations recorded in the entered data file at scale 20 m is presented in Figure 8.14.

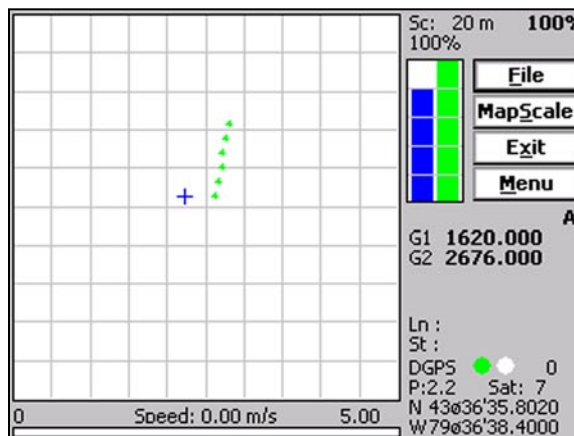

Figure 8.14: Layout of GPS positions from the external file plotted at map scale 20 m

The cross mark indicating position of the system is still approximately in the central position. Positions from external file are always related to the location of GPS when the program (its Logging portion) was started. In order to see more positions in the example in Figure 8.14 the operator can walk N-E or the scale can be changed.

Since only one external file or one ASCII file can be entered the pop up menu will contain item Remove External File (or Remove ASCII file if ASCII file was loaded), Figure 8.15. Tap this item (or use the arrow and ENTER key) to remove the external file from the display and from the program's memory. If the keyboard is used then the key **E** can act as a toggle to load and remove external data file.

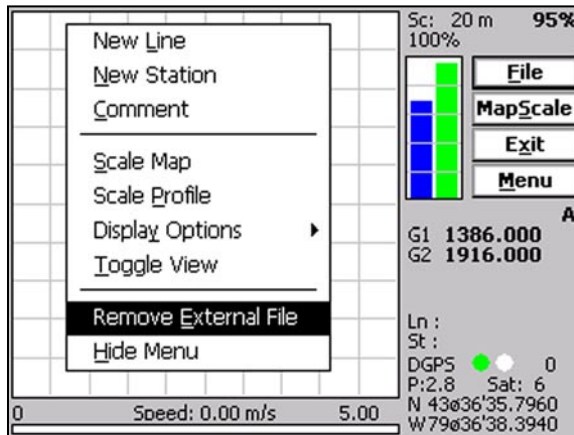

Figure 8.15: Pop up menu with Remove External File item

ASCII File (External data in ASCII text format)

This option of NAV601 allows you to display GPS positions from processed data formatted in ASCII text files organized in comma or space delimited columns. Such files can contain positions of anomalies or targets located during interpretation. Positions can be exported while using Oasis or other mapping software. In Geosoft this type of files can be easily created by using Digitize function. The only condition is that positions should be saved (or converted) to GPS native coordinate system - Geodetic coordinates (Latitude/Longitude) in WGS1984. This option is useful in cases where the operator wants to locate previously located anomalies, navigate toward any features of known coordinates, or to increase density of stations in vicinity of previously detected targets.

After the pop up menu item ASCII File is tapped or executed from the keyboard (either by navigating with arrow keys or by pressing the **I** key) the standard Windows Open File dialog is displayed (Figure 8.16). File name must

include extension file name (i.e. TXT, DAT, POS, etc.). Specify file name using the Windows standard interface procedure.

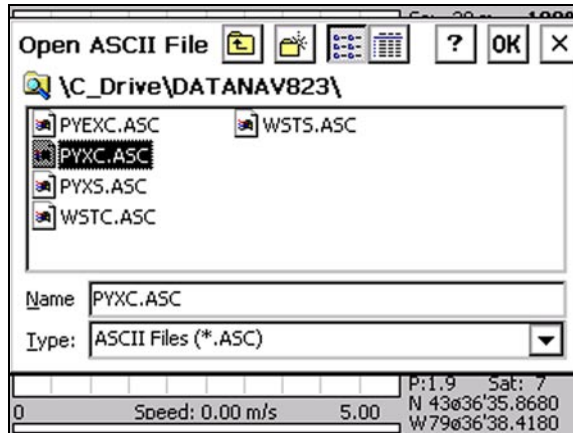

Figure 8.16: Open ASCII File dialog

After the file is selected the program will display dialog ASCII File Parameters (Figure 8.17). Numbers of column containing Longitude and Latitude, and type of delimiter (comma or space) have to be specified.

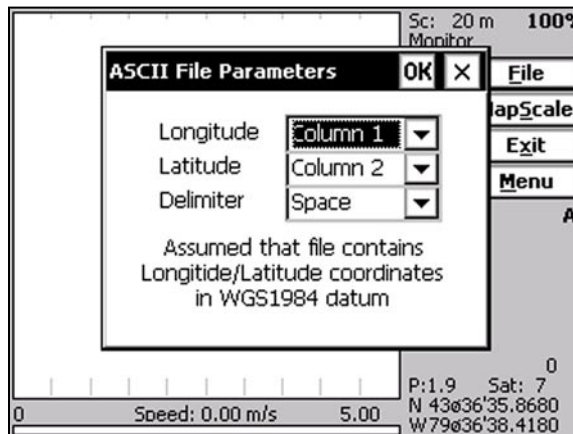

Figure 8.17: ASCII File Parameters dialog

After ASCII File parameters are specified a message with number of positions in the file will be displayed. At the same time depending on the available memory the program will provide a number of positions that will be displayed (Figure 8.18). ASCII files usually contain relatively small number of positions. In rare cases when all positions can not be displayed at the same time, the program will plot every second, or third (and so on) GPS position, however the first

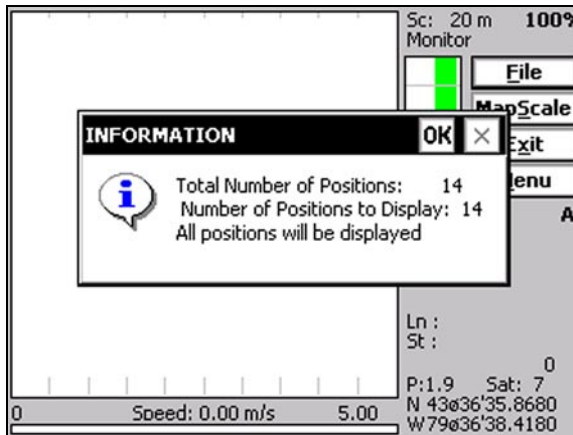

Figure 8.18: Number of Positions to be displayed

and last stations recorded in the file will be always plotted. To display all points (contained in a large file) please divide file to two or more data sets. After confirming above message by pressing any key the program starts to display positions recorded in the entered file. This operation can take several seconds depending on the file size and scale of the map area. Therefore message labeled **WAIT** located at the right side of plot area will remain till all positions are displayed. In addition a beep will signal the end of plotting. Layout of GPS stations recorded in the entered data file is presented in Figure 8.19.

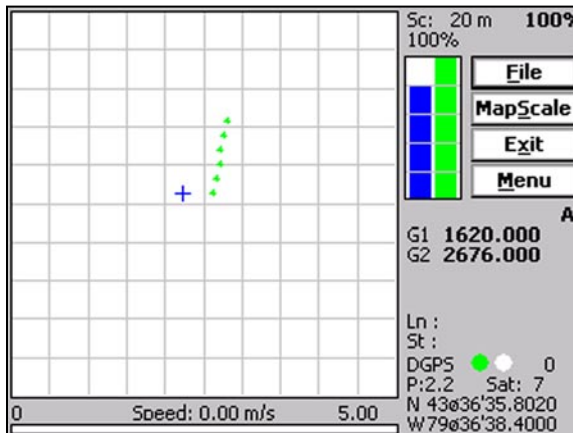

Figure 8.19: Layout of GPS positions from the ASCII file plotted at map scale 20 m

The cross mark indicating position of the system is still in the central position. Positions from external file are always related to the location of GPS when the program (its Logging portion) was started. Since only one ASCII file or one External file can be entered the pop up menu will contain item Remove ASCII File (or Remove External file if external data file was loaded), see similar Figure 8.15. Tap this item (or use the arrow and ENTER key) to remove the external file from the display and from the program's memory. If the keyboard is used then the key **I** can act as a toggle to load and remove external data file.

Exit (exit Monitor mode)
 After tapping the **Exit** button (or executing this option using keyboard) the program immediately returns to Main Screen.

8.3 Stand By Mode

The main difference between the Monitoring and Stand By modes is that from the Stand By mode the program can be directly switched to Log mode to record the data in the file. The Allegro CX screen in Stand By mode in Navigation display mode is shown in Figure 8.20. The layout of the screen is almost identical to the layout described in section 8.1. Main differences are: label **Stand By**, reminding the operator about current mode, different command buttons and additional pop up menu options specific to this mode, and file name shown (label **F** below moving bars window).

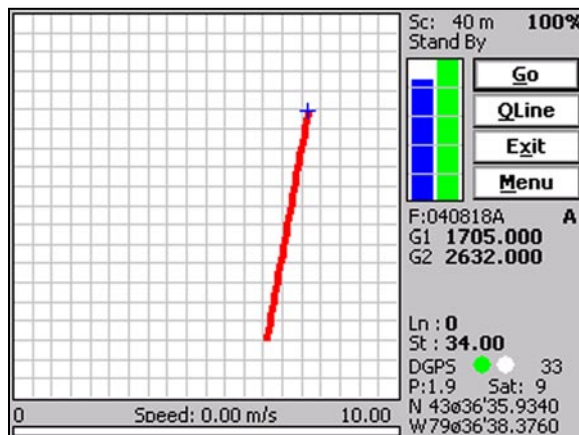

Figure 8.20: The NAV601 screen in the Stand By mode and Navigation display mode

Example shown in Figure 8.20 presents situation where the operator started to walk in the N-E direction while logging data and then stopped logging data by switching from Log to Stand By mode. In the Stand By mode the cross mark which represents position of the operator (GPS antenna) will move if the operator will change his location, however points corresponding to GPS locations will not be plotted.

In case the program is run in the Profile display mode, data recorded previously in Log mode (up to last 198 stations before switching to Stand By mode) will be shown as profiles in the plotting area, as shown in Figure 8.21. Similarly to Navigation mode where GPS locations are not plotted on the screen, data plotted in profile form will not be updated in Stand By mode.

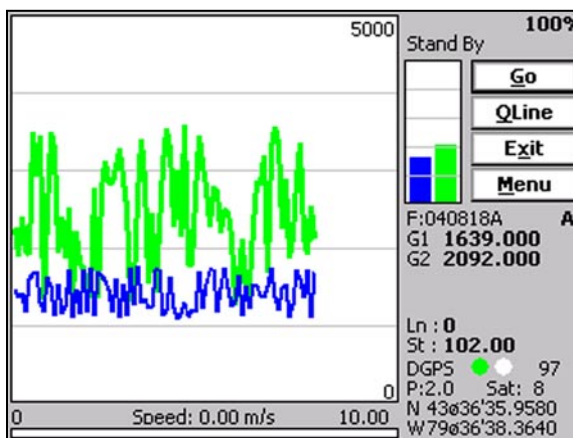

Figure 8.21: The NAV601 screen in the Stand By mode and Profile display mode

The Grad601 data displayed in the grid with moving bars and by numeric values will be displayed with the update rate approximately 10 readings per second, however data will not be saved in the log file in Stand By mode. If GPS input was enabled, GPS positions and parameters will be updated with a rate specified in GPS receiver. GPS data are not saved in file in Stand By mode as well.

Four command buttons available in Stand By mode include: **GO** (executed by tapping, or pressing key **G** or **ENTER** if the button is highlighted) which directs the program to Logging mode and recording Grad601 and GPS data, **QLine** (Quick Line), **Exit**, and **Menu** (which contains more options than pop up menu in Monitoring mode). These options are described in detail in Section 8.5 (Field options available in Stand By mode).

8.4 Logging Mode

The Logging mode is enabled by tapping on the **GO** button or pressing the shortcut key **G** (or the **ENTER** key if the button **GO** is highlighted) in Stand By mode. After this button is executed the list of four buttons will be replaced by one "Pause" button, label Stand By will be replaced by label **Logging** (at the top of the display) and data will be logged in the mode corresponding to the selected Grad601 mode in the Survey Setup menu. All labels and parameters (with the exception of buttons representing Stand By mode options) are the same as in Stand By mode and they are described in the preceding section 8.2. The NAV601 screen in Logging mode and in Navigation display mode is presented in Figure 8.22. The cross mark corresponding to the system location will move while the operator is progressing along the survey line and recorded GPS positions will be plotted as dots on the screen.

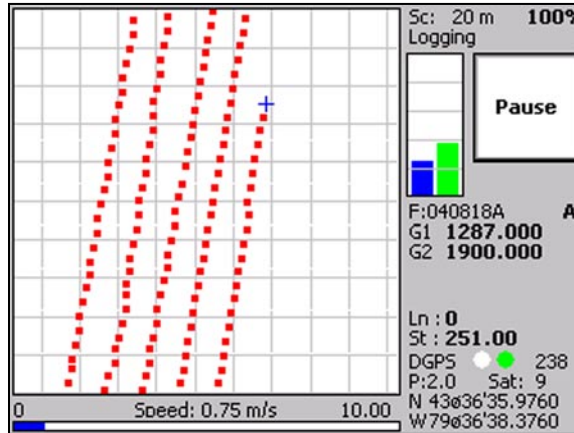

Figure 8.22: The NAV601 screen in Logging mode (Navigation display mode)

If the program's display was toggled in Stand By mode to Profile display mode or if GPS was disabled in GPS Input menu the NAV601 Profile display mode will be used as shown in Figure 8.23.

When the Profile display mode is enabled profiles (or profile) curves are updated after each reading is written to the data file. The program displays profiles for sensor readings that were selected in the Profile Display Options window. Regardless of the latter selection all readings will be saved in the data file and displayed in the grid with moving bars as well as in digital form, however corresponding profile will not appear on the screen.

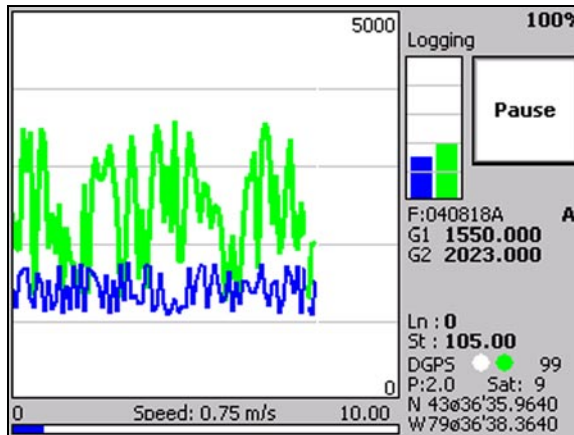

Figure 8.23: The NAV601 screen in Logging mode (Profile display mode)

After the screen changes from Stand By to Logging mode the current station (label **St**) is updated according to the station interval. Similarly, if the GPS input was enabled, the total number of GPS positions in the data file is incremented every time (usually once a second) GPS position is written to the file (number of GPS records follows label **DGPS** or **AGPS**, and a small circle flashes green colour). Amplitude of graphic bars in grid area and digitally displayed readings for the instrument are updated after each reading is written to the data file. The audible click sounds at each reading if Audio option was selected in the Logger Setup dialog.

There is only one option available in the Logging mode - PAUSE logging. After the button labeled PAUSE is tapped or a Pause key selected in the Logger Setup dialog is pressed the recording is stopped and the Logging screen returns to the Stand By mode. In the Stand By mode the Grad601 data will be displayed with the update rate approximately 10 readings per second, however data will not be saved in the log file, profile plots will not be updated (in Profile mode), audible click will stop if Sound option was enabled.

The cross mark corresponding to the system location will move according to the operator movement, however GPS positions will not be plotted as dots on the screen.

8.5 Field Options Available in Stand By Mode

Several options are available while the Logging window is in the Stand By mode. Four frequently used options can be accessed directly from command buttons and others can be used from pop up menu activated by button **Menu** (displayed in Figure 8.24). Command buttons can be used by tapping on the desired button, or from the keyboard by pressing one of the shortcut keys (underlined characters on button labels) or by navigating using **TAB** key (sets button as a default button - default button is highlighted) and pressing **ENTER** key.

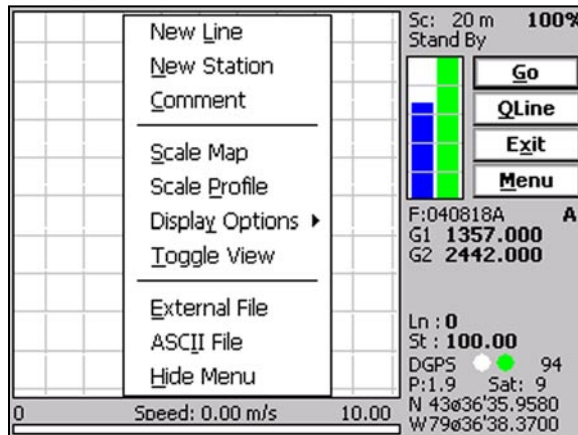

Figure 8.24: List of items in pop up menu in Stand By mode

Options listed in the menu can be accessed directly (without displaying pop up menu from the **Menu** button) by using keyboard shortcuts (underlined characters in menu items), i.e. pressing key **C** will display Enter Comment dialog. While the pop up menu is displayed options can be selected by clicking on the appropriate proper option, or from the keyboard by pressing the shortcut keys or by navigating using **Up** and **Down** arrow keys and then executing by the **ENTER** key.

GO (start data logging)

Tap on the **GO** button, or while using the keyboard press shortcut key **G** or if the button is a default button (highlighted) press **ENTER** key. The logging window in Stand By mode will change to Logging mode and logging data starts immediately.

QLine (*Quick Line change*)

Tap on the **QLine** button, or while using the keyboard press shortcut key **Q** or if the button is a default button (highlighted) press **ENTER** key. The confirmation message will be displayed, Figure 8.25.

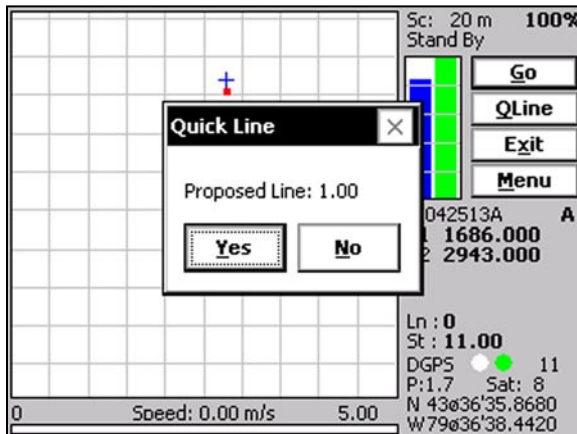

Figure 8.25: *Quick Line confirmation message*

This option allows the operator for fast and convenient change of the survey line, assuming that formerly specified parameters describing survey procedure can be accepted. In case of GPS based survey, this option provides very convenient and fast (two key strokes) procedure of dividing large data sets to several survey lines, without displaying the New Line dialog.

The name of the new line is given by the program based on the former line name and Line Increment (see Survey Setup dialog or the New Line option). Start station and Station Increment of the new survey line is calculated by the program base on the Sequence parameter and former line Start Station and Increment (see Survey Setup dialog or option New Line that follows).

To accept proposed Survey Line name tap on the **Yes** button or press **ENTER** key. If the button **No** is tapped then the program will continue survey along existing survey line.

New Line (New Survey Line)

The New Line dialog is displayed, Figure 8.26. Selecting this option allows the operator to enter a new survey line number (name) and (as opposite to Quick Line described above) to change associated line parameters (Line Increment, Line Sequence, Direction, Start Station, and Station Increment). The new line number and associated parameters are prompted by the program based on parameters specified in the Survey Setup menu and the last survey line.

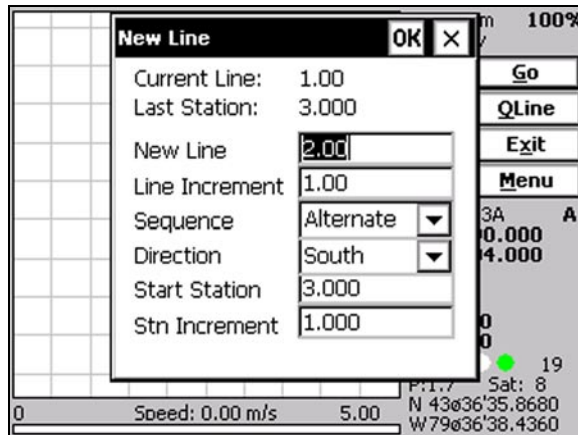

Figure 8.26: The New Line dialog

At the top of the dialog the last survey line name and the last logged station are displayed. Default name for the new line is given based on the Line Increment parameter. The default Start Station, direction of the Station Increment, and Direction are determined based on Sequence selection. All these parameters can be overwritten by the user as described in the Survey Setup dialog description (chapter 3).

After all the parameters in the New Line dialog are updated tap the button **OK** or press **ENTER** key to accept the displayed settings. The program will return to the Logging window in Stand By mode. Survey line (**Ln:**) name and current station (**St:**) value will be updated and if the program is in Profile mode then profile curves plot for former survey line will disappear.

To return to Stand By mode and current survey line settings (state before this dialog was selected) tap **Cancel (X)** button or press **Esc** key, the dialog window will disappear.

New Station

Selecting this option allows the operator to enter a new station number (within the same survey line). The New Station dialog is displayed and it is shown in Figure 8.27. New station can be used in situation when an obstruction does not allow for continuation of the survey line. A new station can be entered and survey line can be continued. An alternative option in this case would be to use a new line with the same name and affix i.e. 11A, 11B, and so on. Start and Current station are displayed at the top of the dialog. The New Station can be entered in the provided edit box labeled New Station.

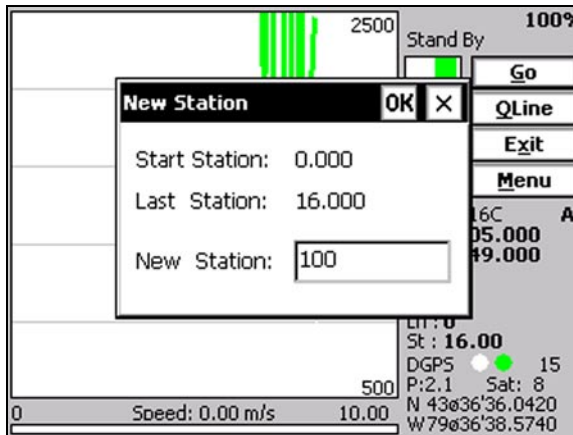

Figure 8.27: New Station dialog

Tap the button **OK** or press **ENTER** key to accept the new value. The program will return to the Logging window in Stand By mode. Current station (**St:**) value will be updated and after data logging is activated the profile curves (if the program is in Profile mode) will have a small gap (and possible amplitude discontinuity) showing the new station entry (see Figure 8.28).

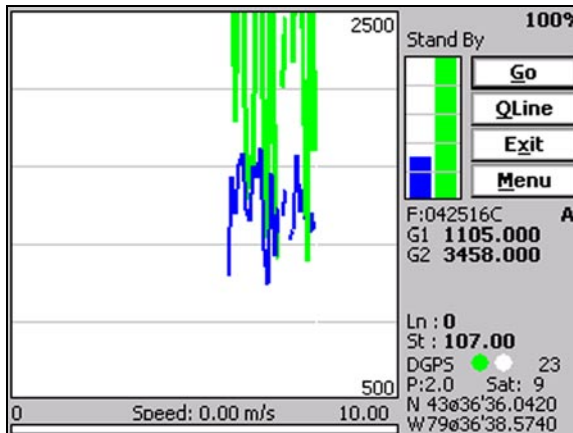

Figure 8.28: Profile display after New Station was entered

To return to Stand By mode and current survey line settings (state before this dialog was selected) tap **Cancel (X)** button or press **Esc** key, the dialog window will disappear and measurements can be continued.

Comment

The Comment option allows the operator to enter a comment at any point of the survey. A maximum of 11 characters can be entered as a comment. The Enter Comment dialog is displayed in Figure 8.29.

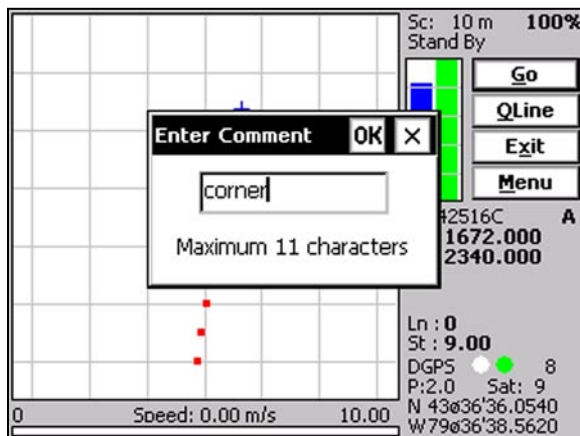

Figure 8.29: Enter Comment dialog

Tap the button **OK** or press **ENTER** key to accept the comment entered in a text box of the dialog. The text of the comment is saved in the file with a corresponding time stamp and the program will return to the Logging window in Stand By mode.

To ignore an entry and return to Stand By mode tap **Cancel (X)** button or press **Esc** key, the dialog window will disappear and measurements can be continued.

Map Scale

This option is available by tapping on the command button labeled **Map Scale**, from pop up menu (accessible from **Menu** button), or directly from keyboard by using shortcut key **S**. The Enter Map Scale dialog will appear on the screen, Figure 8.30.

This dialog allows the operator to enter new scale for the map displayed by the plot area. Value is entered either in meters or feet according to selected units in Logger Setup dialog and it represents side of the square map. Only positive integer values ranging between 1 and 9999 are allowed by the program.

The second parameter in the Enter Map Scale is Grid Interval. These are grey grid lines in Navigation mode which may be helpful in estimation of distance on the map displayed in Navigation mode. Maximum number of grid lines is 20 in one direction, therefore minimum grid line interval is (Map Scale)/20, i.e. for the map scale 10 m the minimum grid interval is 0.5 meter. The program will recalculate grid interval in case too large scale will be entered.

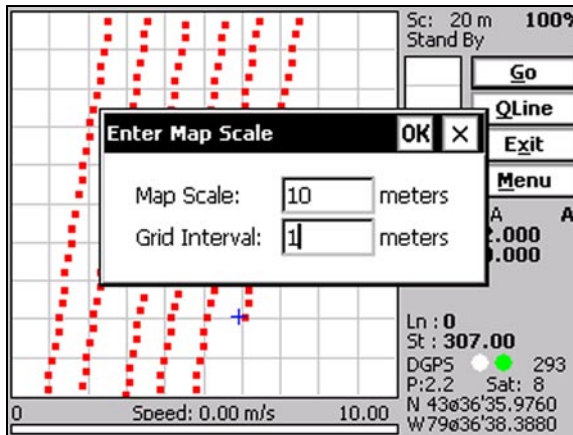

Figure 8.30: Enter Map Scale dialog

Setting Grid Interval to zero will result in lack of any grid lines on the screen. A data set at scale 10 m is shown in Figure 8.31. Compare the same data set presented at scale 20 m (before changing the map scale) in Figure 8.30.

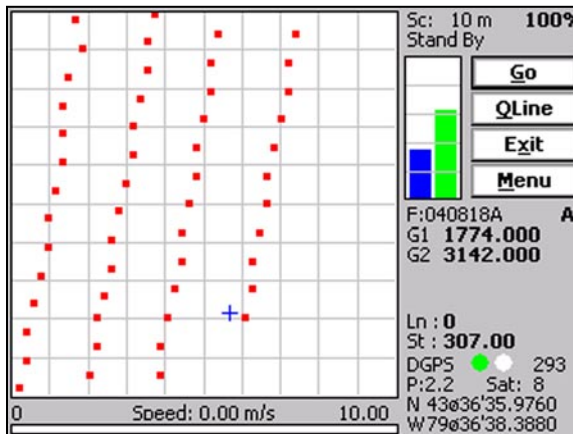

Figure 8.31: The NAV601 screen in Navigation mode after change of map scale

After the file is specified tap the button **OK** or press **ENTER** key to accept and create data file. The program will switch Monitor mode to Stand By mode and the data file will be displayed on the screen.

To cancel selection and return to Monitoring mode tap the **Cancel (X)** button or press **Esc** key.

Profile Scale (conductivity and Inphase scale for profiles and moving bars)

This option is available from pop up menu (accessible by tapping the **Menu** button), or directly from keyboard by using shortcut key **P**. The Enter Profile/Bar Scale dialog will appear on the screen, Figure 8.32.

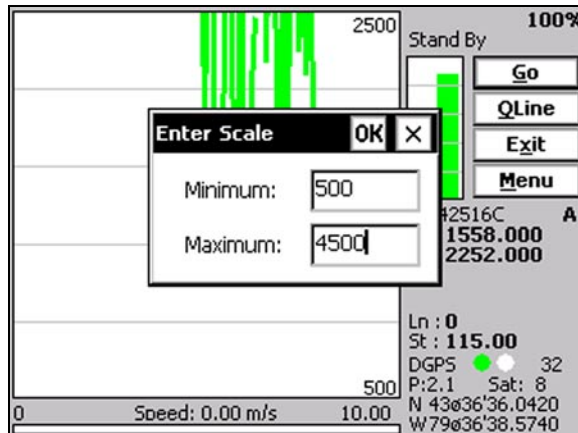

Figure 8.32: Enter Profile and Bar Scale dialog

This dialog specifies scale for profiles as well as for grids with moving bars. Minimum and maximum values can be specified for the plot range in the graphic window containing two moving bars as well as for the profile plot display if the Monitoring screen is in Profile display mode. Therefore range of displayed data is the same for the profile display area and for the area with vertical bars. However only profile plot area is labeled at its right side (Figure 8.33).

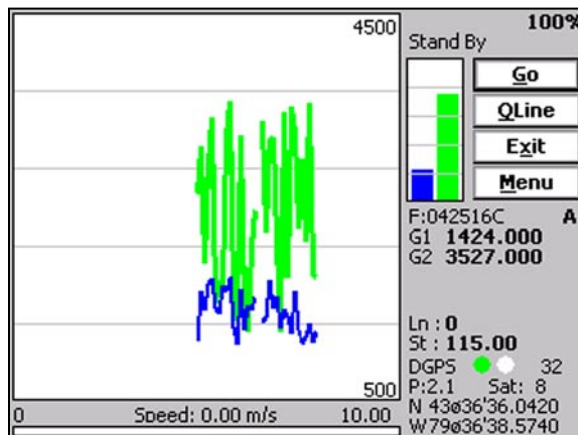

Figure 8.33: Profile display in new scale (compare with Figure 8.32)

After minimum and maximum values for each component are specified tap the button **OK** or press **ENTER** key to accept new values and the display will be re-drawn (see below Figure 8.33 with scale 0 to 400 nT and compare profiles shown in Figure 8.32, where scale 0 to 250 nT was used).

To cancel selection tap the **Cancel (X)** button or press **Esc** key.

Display Options (Map Options, Profile Options, and Speed Bar)

The Display Options item has three submenus. These are Map, Profile, and Speed Bar. Items Map and Profiles are identical to Map Display Options and Profile Display Options described in detail in Chapter 7. They can be accessed from pop up menu or directly by the keyboard pressing **A** or **R** keys.

Scale Speed Bar (adjust scale for speed bar)

The minimum value for the Speed Bar is preset to 0, therefore this scale requires only entry for the maximum speed. The Speed Bar Scale is given in Figure 8.34.

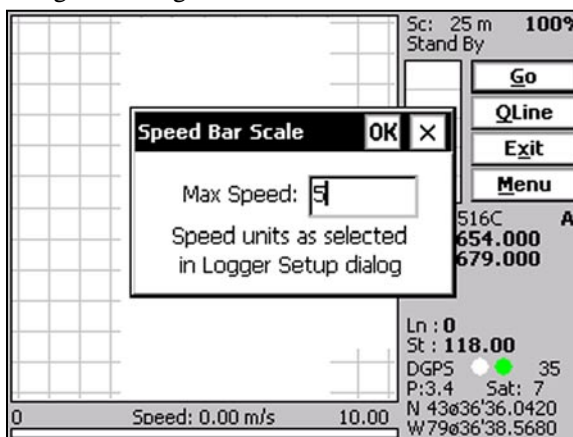

Figure 8.34: Speed Bar Scale dialog

The entered scale applies only to graphic representation of the speed (graphic bar), speed in numeric form is always displayed above the bar, even if the real value exceeded maximum specified for the speed bar. After the maximum value for the speed bar is specified tap the button **OK** or press **ENTER** key to accept new values and the display will be re-drawn. To cancel selection tap the **Cancel (X)** button or press **Esc** key.

Toggle View (toggle between Navigation and Profile modes)

Selecting this item from pop up menu or simply pressing the key **T** will switch Monitoring or Stand By screens between Profile and Navigation modes. Changing the display from Profile to Navigation mode may take several seconds

(depending on number of positions displayed and map scale). The program will display message WAIT till all positions are plotted in current map area and it will beep at the end of this process.

External File (External TrackMaker Data or GXY File entry)

This option allows to display GPS positions from formerly acquired data file. Files created with NAV601, as well as data or GXY files created with any other Geomar data acquisition programs (i.e. NAV61, NAV38, ML61, etc.) can be entered. This option is useful in cases where the operator wants to review the coverage of the surveyed area, to find the last station surveyed in a previous day, cover an area already surveyed with different instrument, or simply to increase density of stations in previously surveyed area.

After the item is selected from pop up menu or from the keyboard (by pressing the E key) the standard window dialog Open File is displayed (Figure 8.35). File name must include extension file name (i.e. 601, H31, N61, GXY, etc.). Specify file name using the Windows standard interface procedure.

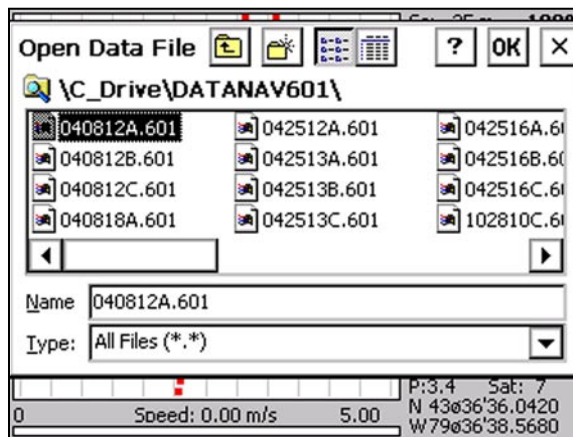

Figure 8.35: Open External File dialog

After the file is selected a message with number of positions in the file will be displayed. At the same time depending on the available memory the program will provide a number of positions that will be displayed (Figure 8.36). If all positions can not be displayed, then the program will plot every second, or third (and so on) GPS position, however the first and last stations recorded in the file will be always plotted.

After confirming this message by tapping the button **OK** or pressing **ENTER** key the program starts to display positions recorded in the entered file. This operation can take several seconds depending on the file size and scale of the map area. Therefore message labeled WAIT located at the right side of plot area will

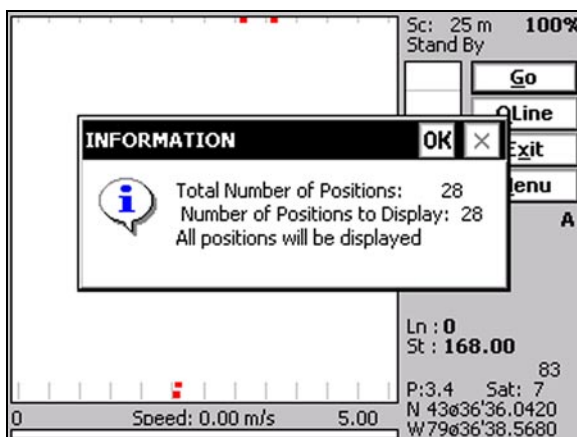

Figure 8.36: Number of Positions to be displayed

remain till all positions are displayed. In addition a beep will signal the end of plotting. Layout of GPS stations recorded in the entered data file at scale 30 m is presented in Figure 8.37.

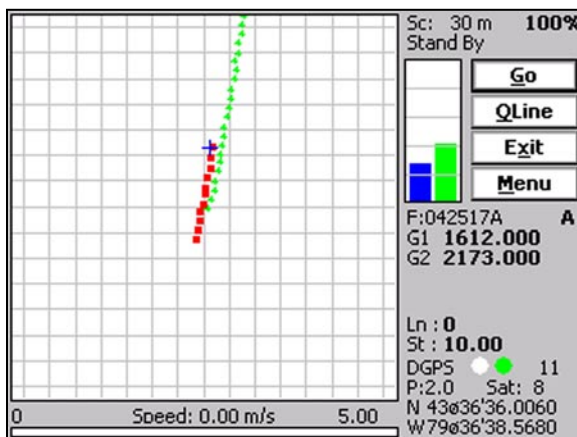

Figure 8.37: Layout of GPS positions from the external file (smaller green dots) and currently collected positions (larger red dots) plotted at map scale 30 m

The size and colour of external file positions as well as current GPS positions are specified in Map Display Options (see Chapter 7). In the example in Figure 8.37 currently collected GPS points are represented by red and larger dots while entered GPS positions from external file are plotted by green and smaller dots. Since only one external file or one ASCII file can be entered the pop up menu

will contain item Remove External File (or Remove ASCII file if ASCII file was loaded), Figure 8.38.

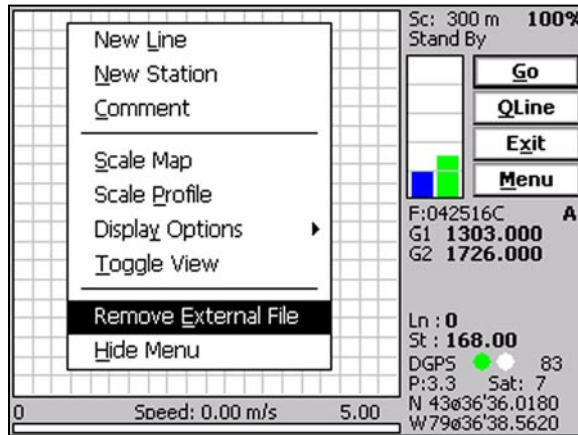

Figure 8.38: Pop up menu with Remove External File item

Tap the Remove External File item in pop up menu (or use the arrow and ENTER key) to remove the external file from the display and from the program's memory. If the keyboard (without displaying menu) is used then the key E can act as a toggle to load and remove external data file.

ASCII File (External data in ASCII text format)

This option of NAV601 allows you to display GPS positions from processed data formatted in ASCII text files organized in comma or space delimited columns. Such files can contain positions of anomalies or targets located during interpretation. Positions can be exported while using Oasis or other mapping software. In Geosoft this type of files can be easily created by using Digitize function. The only condition is that positions should be saved (or converted) to GPS native coordinate system - Geodetic coordinates (Latitude/Longitude) in WGS1984. This option is useful in cases where the operator wants to locate previously located anomalies, navigate toward any features of known coordinates, or to increase density of stations in vicinity of previously detected targets. After the pop up menu item ASCII File is tapped or executed from the keyboard (either by navigating with arrow keys or by pressing the I key) the standard Windows Open File dialog is displayed (Figure 8.39). File name must include extension file name (i.e. TXT, DAT, POS, etc.). Specify file name using the Windows standard interface procedure. After the ASCII file is selected the program will display dialog ASCII File Parameters (Figure 8.40). Numbers of column containing Longitude and Latitude, and type of delimiter (comma or space) have to be specified.

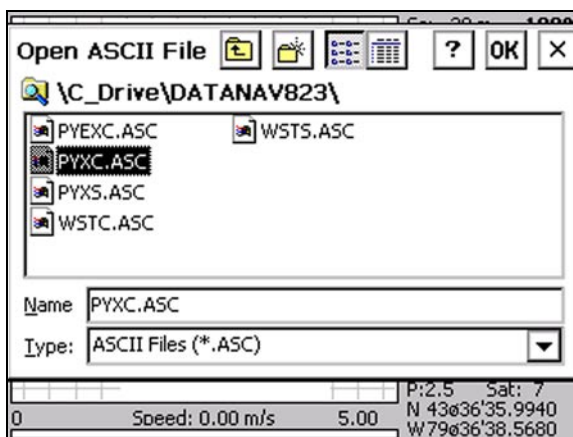

Figure 8.39: Open ASCII File dialog

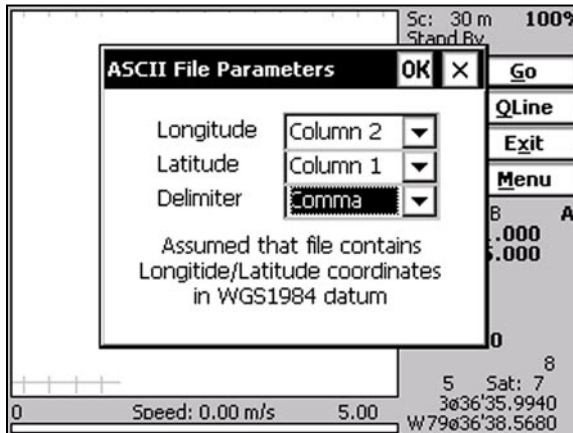

Figure 8.40: ASCII File Parameters dialog

After ASCII File parameters are specified a message with number of positions in the file will be displayed. At the same time depending on the available memory the program will provide a number of positions that will be displayed (Figure 8.41). ASCII files usually contain relatively small number of positions. In rare cases when all positions can not be displayed at the same time, the program will plot every second, or third (and so on) GPS position, however the first and last stations recorded in the file will be always plotted. To display all points (contained in a large file) please divide file to two or more data sets. After confirming above message by pressing any key the program starts to display positions recorded in the entered file. This operation can take several seconds depending on the file size and scale of the map area. Therefore message

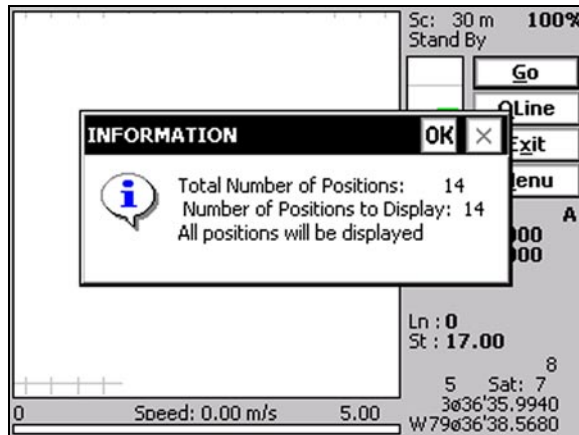

Figure 8.41: Number of Positions to be displayed

labeled **WAIT** located at the right side of plot area will remain till all positions are displayed. In addition a beep will signal the end of plotting. Layout of GPS stations recorded in the entered data file is presented in Figure 8.42.

The size and colour of ASCII file positions as well as current GPS positions are specified in Map Display Options (see Chapter 7). In the example in Figure 8.42 currently collected GPS points are represented by red and smaller dots while

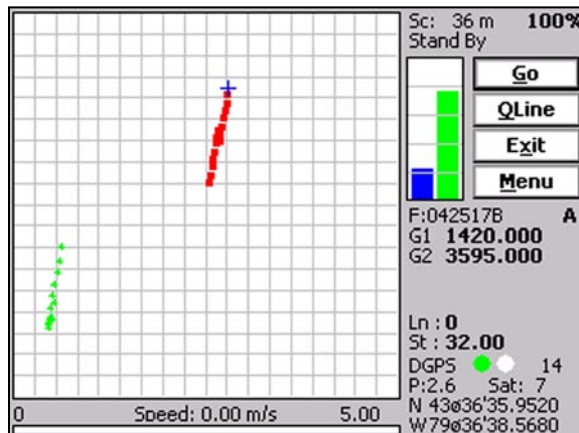

Figure 8.42: Layout of GPS positions from the ASCII file plotted at map scale 36 m

entered GPS positions from external file are plotted by green and larger dots. Since only one ASCII file or one External file can be entered the pop up menu will contain item Remove ASCII File (or Remove External file if external data file was loaded), see similar Figure 8.38. Tap this item (or use the arrow and ENTER key) to remove the external file from the display and from the pro-

gram's memory. If the keyboard is used then the key **I** can act as a toggle to load and remove external data file.

Exit (exit data logging)

During data collection (in Stand By mode) a confirmation message will be displayed (there is no such message if **Exit** is performed in Monitoring mode) before program exits logging window, Figure 8.43.

After above message is confirmed the program stops logging, closes data file and returns to Main Screen. If the button No is tapped the program returns to current logging mode and data collection can be continued.

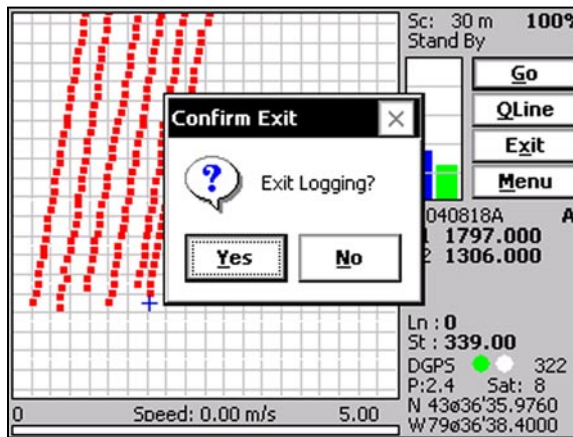

Figure 8.43: Exit Logging session confirmation

8.6 Message NO CONNECTION

If data is monitored or logged (in Monitoring, Stand By, or Log modes) a message **NO CONNECTION** (Figure 8.44) may appear in the centre of the screen when connection with the Grad601 is lost. This message is preceded by four messages **PLEASE WAIT**.

This indicates lack of communication between the Grad601 instrument and the field computer. In most cases the message **NO CONNECTION** is caused by disconnected connector in the instrument cable, turning the instrument OFF or low battery in the Grad601. The NAV601 tries to establish communication while messages **PLEASE WAIT** are displayed. When message **NO CONNECTION** is displayed all open files are closed and after pressing any key the program ends. After correcting the source of a problem start the NAV601.

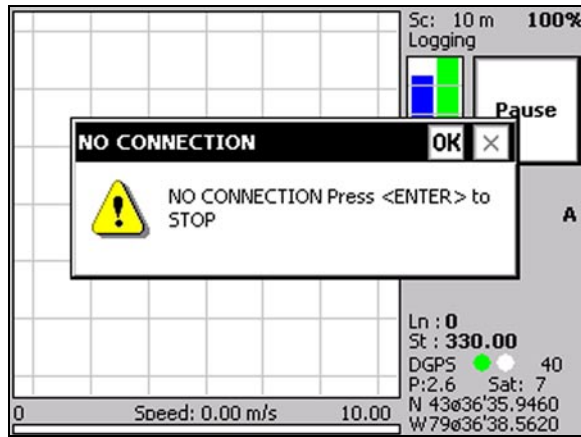

Figure 8.44: The NO CONNECTION message during Logging mode

The NAV601 will be stopped when maximum number of GPS positions in the data file is reached and corresponding message will be displayed (Figure 8.45). There is no limit for Grad601 data, however the maximum number of GPS stations in the file is 14400. Please try to limit you files to 1 hour worth of data. When number of GPS positions is large it takes longer for the processor to redraw screen, organize and sort coordinates in the internal data base.

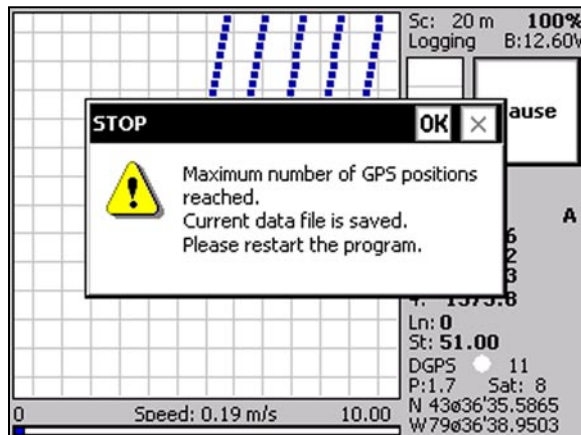

Figure 8.45: The NAV601 message when maximum number of GPS positions in one data file has been reached

NAV601 Data File Format



A.1 Description of NAV601 Data File Format (601)

Each file record contains 27 characters including line feed at the end of each record.

Header of the file contains 3 records starting with characters **N**, **H**, and **G**.

1	2	3	4	5	6	7	8	9	10	11	12	13	14	15	16	17	18	19	20	21	22	23	24	25	26	27
N	A	V	6	0	1			W	1	3	4	Survey Type	UT		IM		IS							svid	10	
H							Data File Name												TG						svid	10
G							GPS X Offset (F7.2)											GR	GP	GS					svid	10

- NAV601 - identification of program file
- W105 - version number V1.34, W indicates Allegro CX
- Survey Type - GPS (if GPS Input Enabled) or GRD (grid)
- UT - unit type (0 = meters, 1 = feet)
- IM - Grad601 survey mode
(0 = Auto, fixed)
- IS - Grad601 type (1 = 1 sensor, 2 = 2 sensors)
- File Name - file name, maximum 8 characters
- Samples - not used
- TG - File tag (space= original, 1= Saved As or/and edited)
- GPS X Offset - Offset of GPS antenna in X direction
- GPS Y Offset - Offset of GPS antenna in Y direction
- GR - GPS update rate (0 = not used)
- GP - type of GPS NMEA message
(0 = GGA/GSA, 1= GGA, 2 = POS, 3 = LLK,
4=LLQ, 5=GLL, 6 = GGK, 7 = Leica TPS,
8=Trimble RTS)
- GS - GPS state (0 = Disabled, 1 = Enabled)
- svid - logger/software type id (not used)
- 10 - Line Feed character

Header at the start of survey line (contains four records starting with L, B, A, and Z)

1	2	3	4	5	6	7	8	9	10	11	12	13	14	15	16	17	18	19	20	21	22	23	24	25	26	27	
L	Line Name - 8 characters																								10		
B	Start Station (Format F11.2)																								10		
A	Dir							Station Increment (Format F11.3)																10			
Z	D	D	M	M	Y	Y	Y	Y		H	H	:	M	M	:	S	S	.	h	h							10

- Line Name** - Line Name, maximum 8 characters
- Start Station**- Start Station for the Line, format F11.2
- Dir** - Direction of the Line (E, W, N, or S)
- Station Inc.** - Station Increment, format F11.3
- Date** - Date when Line was created, format DD-MM-YYYY
- Time** - Time when Line was created, format HH:MM:SS.hh
- 10** - Line Feed character

Timer Reset

1	2	3	4	5	6	7	8	9	10	11	12	13	14	15	16	17	18	19	20	21	22	23	24	25	26	27
*	Computer Time (Format HH:MM:SS.hh)																Time Stamp in ms (10 digits)						10			

Indicates reset time of the program timer. This record links timer in milliseconds and computer time (local time) in format HH:MM:SS.hh. This record is written to the file each time after the program switches from the Stand By to Log mode. In case when data are taken continuously the timer is automatically reset every hour.

Reading

Each instrument record consists of two lines, the first line starts with **T** and the second line starts with **>** .

1	2	3	4	5	6	7	8	9	10	11	12	13	14	15	16	17	18	19	20	21	22	23	24	25	26	27
T	Indicator		Reading 1				Reading 2														10					
>	Readings Counter																Time Stamp in ms (10 digits)				10					

- T** - indicates the first line of instrument record
- Indicator** - \$PBAR (fixed string)

- Reading 1** - four character field containing Sensor #1 output in nT
- Reading 2** - four character field containing Sensor #2 output in nT, if one sensor is used then this field contains spaces
- >** - indicates the second line of the instrument record
- Counter** - six digits field containing sequential number of reading
- Time Stamp** - time stamp of the reading in milliseconds, this is time elapsed from the last timer reset. The time in milliseconds can be linked with the computer local time by using Times in line started by * (see Timer Reset).
- 10** - Line Feed character

Comment

1	2	3	4	5	6	7	8	9	10	11	12	13	14	15	16	17	18	19	20	21	22	23	24	25	26	27
C	Comment (maximum 15 characters)															Time Stamp in ms (10 digits)										10

New Station

1	2	3	4	5	6	7	8	9	10	11	12	13	14	15	16	17	18	19	20	21	22	23	24	25	26	27		
S	New Station (Format 11.2)																	Time Stamp in ms (10 digits)										10

GPS Data Message Records

Each GPS record (GGA Message) is broken in to several 22 characters strings and placed in the NAV601 data file which contains 24 characters records, including one character indicator and line feed at the end of each record. The GPS sequence starts at the line which contains the character @ as the first character, then records that contain a continuation of the same message start with the character #. The GPS sequence ends with a line starting with the character !. The last line contains sequential number of GPS recorded position and a logger time stamp for the given GPS reading. A sample of the GPS message written in NAV601 format is given below.

1	2	3	4	5	6	7	8	9	10	11	12	13	14	15	16	17	18	19	20	21	22	23	24	25	26	27
@	\$	G	P	G	G	A	,	h	h	m	m	s	s	.	s	s	,	d	d	m	m	.	m	m	m	10
#	m	m	,	s	,	d	d	d	m	m	.	m	m	m	m	m	,	s	,	n	,	q	q	,	p	10
#	p	.	p	,	s	a	a	a	a	a	.	a	a	,	u	,	±	x	x	x	x	.	x	,	M	10
#	,	s	s	s	,	a	a	a	*	c	c	CR	LF											10		
!	0	0	4	3	5											Time Stamp in ms (10 digits)										10

The GPS sequence may contain 4 to 7 records. The components of the GGA message may differ in length, however they are placed in the same number of columns. Refer to Appendix B (section B.2) for the definition of each component of the GGA data message. Other available GPS messages in NMEA format, GSA, POS, LLK, LLQ, GLL, and GGK, are recorded similarly. The structure of these NMEA sentences is given in section B.2 of Appendix B.

If the Checksum in NMEA message is invalid then starting character @ is replaced by ?, and # is replaced by " (ASCII character code 34). The starting character of Time Stamp record ! remains the same.

A.2 Example of NAV601 Data File

The NAV601 data file records are written in binary format, therefore characters may have a different shape when displayed or printed, depending on particular video or printer settings.

```
NAV601 W130GPS0 0 2 02
H 052012A 0.200 2C
G 0.00 0.00 001 FE
LO
B 0.00
AS 1.000
Z20052008 12:47:53
*12:47:53.000 147944
X$STARTED 149140
T$PBAR,1130,2504
>000001 149186
T$PBAR,1320,2607
>000002 149296
T$PBAR,1430,2603
>000003 149406
T$PBAR,1550,2307
>000004 149516
T$PBAR,1650,2457
>000005 149626
T$PBAR,1733,2507
>000006 149736
T$PBAR,1840,2767
>000007 149845
@$GPGGA,182702.00,4336.593
#81,N,07936.64493,W,2,7,2,
#141.84,M,-35,M,4,118*5D
!000001p 149880
@$GPGSA,A,3,32,,22,,18,14
#,12,,09,05,,02.5,01.5,01.
#9*0B
!000001 149915
T$PBAR,1920,2534
>000008 149955
T$PBAR,1330,2307
>000009 150065
T$PBAR,1300,2534
>000010 150175
T$PBAR,1200,2207
>000011 150285
T$PBAR,1200,3407
>000012 150395
T$PBAR,1100,2507
>000013 150505
T$PBAR,1300,3607
>000014 150615
```

A.3 Format of GXY Data File

The NAV601 data file with extension GXY contains GPS records. The structure of this file is identical to the standard NAV601 (601) file. The difference is that it does not contain any Grad601 records. This file is created by NAV601 when Grad601 is Disabled in the System Setup menu. In this case the program acts as a GPS logging program.

It should be noted that any NAV601 data file, as well as GXY and data files created by other Geomar data acquisition programs (NAV38, NAV61, ML61, ML31, etc.) can be used as an GXY file in the data processing programs TrackMaker601 and TrackMaker for any other supported Geonics instrument (TrackMaker38, 61, etc.). The extension name GXY indicates that the file does not contain electromagnetic data.

NAV601 and GPS Input

B

B.1 Using the NAV601 with a GPS System

The NAV601 program accepts input from GPS systems that stream NMEA-0183 compatible data through their output port. The program can use the following NMEA messages: pair GGA and GSA, GGA, POS, GLL, LLK, LLQ, and GSK. In addition to GPS NMEA statements NAV601 provides also interface to Leica Robotics Total Station TPS1100 and TPS1200, and Trimble RTS for areas where GPS signal is not accessible. To use Leica Robotics device select option "Leica TPS" in NMEA Data of the GPS Port Setup menu, and when Trimble RTS is employed select item "Trimble RTS". The program writes entire message (that was selected in GPS Input menu) to the NAV601 data file. If the pair GGA/GSA is selected, both GGA and GSA messages are written to the NAV601 data file. The GSA message is used to display index PDOP (Position Dilution of Precision) on the logger screen and to determine quality of GPS position while processing data in the program TrackMaker601.

The GPS system means (control device, receiver panel, or manufacturer software) must be used to set GPS receiver communication parameters, to specify frequency of GPS output, and number and type of NMEA messages sent by the GPS system output port. Any GPS system can send various NMEA messages. **It is important to select only messages (GGA, POS, GLL, LLK, LLQ, GSK, or GGA and GSA) that are actually used by NAV601.** The program will accept any GPS string sent by the GPS receiver, however it uses time to process GPS data that is not being used. Therefore, selecting a larger number of NMEA messages for GPS output will result in slower data acquisition of data. Normally, the NAV601 running in Allegro CX logger uses less than 100 ms to process and record GPS data from the two NMEA messages, GGA and GSA.

If the particular GPS receiver is capable of sending data more than once a second, the program limits its real time output frequency to a maximum 1 Hz or 2 Hz (user selectable). At higher frequency of GPS data the program would be occupied by GPS activity and would not record all required Grad601 data. The restriction of 1 or 2 Hz applies only to the Allegro display update rate in real time. When a GPS receiver streams more than 1 or 2 positions per second **all** GPS positions are saved in the data file and will be used by data processing program TrackMaker601.

To achieve higher speed of data acquisition it is also recommended to use single NMEA message (i.e. POS, LLK, GGK, or just GGA). In addition, if it is possible set faster Baud Rate for GPS, i.e. 19200 or 38400 instead of default value of 9600.

If the pair GGA/GSA is selected, only message GGA is necessary to position Grad601 data. If message GSA is not available in a particular system, the NAV601 will function and record position data based on GGA message. Lack of GSA message will result in PDOP index displayed as Not Available (N/A) on the logger display. In this case it is better to select the message GGA which will provide display of index HDOP (Horizontal Position Dilution of Precision).

The NAV601 displays several parameters related to GPS status. A label **DGPS** (Differential Global Positioning System) in the program indicates that GPS readings are differentially corrected in real time. Label **AGPS** (Autonomous Global Positioning System) in NAV61 indicates lack of differential correction. There are three more labels **RTK3**, **RTK4**, and **RTK5** (RTK - Real Time Kinematic) and they correspond to GPS Quality Indicator 3, 4, and 5. Correction AGPS corresponds to Quality Indicator 1, and DGPS represents Quality Indicator 2. Corrections described by RTK1 to RTK5 correspond to Quality Indicator 3, 4, and 5 (they have often different names for different brands of GPS receivers). See next section B.2 and GPS receiver documentation for detailed description and availability of this parameter.

On the right side of labels **DGPS**, **AGPS**, or **RTK** two small circles are displayed. These circles should change colour between green and white (alternate) with the frequency of GPS update rate (usually 1 second intervals). If circles do not alternate colors for a long period of time (several seconds) it means that the GPS system is not working or that it is not connected to the field computer. The number of recorded GPS positions are displayed on the right side of the small green/white circle. This number is updated only in logging mode, when the data are recorded (in Stand By mode or during Monitoring the moving square, updated GPS positions, index PDOP, and number of tracked satellites, indicate presence of GPS input).

Two more GPS parameters are displayed on the logger screen. These are index PDOP shown by label **P** (or **PDOP**) and number of tracked satellites represented by label **S**. The index called PDOP (Position Dilution of Precision) measures the strength of satellite coverage for a given area. PDOP is affected by the number of satellites visible and their relative positions in the sky. The smaller the number of PDOP the stronger the satellite coverage is. When there are more than 5 satellites widely spaced visible, the PDOP is 4 or less. However, when there are less satellites visible, or they are unevenly spaced in the sky, PDOP values can be 6 or higher. In most cases, the PDOP in open sky is less than 3, and most accuracies given for many GPS systems are given for this norm.

The index called HDOP is related only to horizontal position fix. It is used when message GGA was selected. If a message GGL was selected the index PDOP nor HDOP are not available.

Refer to GPS documentation and literature for more information related to error sources of GPS positioning.

B.2 Description of Selected NMEA Data Messages

GGA Data Message

The GGA message contains the GPS position information and it is the most widely used NMEA data message. This message takes the following form:

**\$GPGGA,hhmmss.ss,ddmm.mmmmm,s,dddmm.mmmmm,s,n,qq,pp.p,saaaa.aa,u,
±xxxx.x,M,sss,aaaa*cc<CR> <LF>**

Definition of GGA message component:

hhmmss.ss	UTC time in hours, minutes, seconds of the GPS position
ddmm.mmmmm	Latitude in degrees, minutes, and decimal minutes
s	s=N or s=S, for North and South latitude
dddmm.mmmmm	Longitude in degrees, minutes, and decimal minutes
s	s=E or s=W, for East and West longitude
n	Quality indicator, 0 = no position, 1 = raw, no differentially corrected position, 2 = differentially corrected position, 9 = position computed using almanac information
qq	Number of satellites used in position computation
pp.p	HDOP = 0.0 to 99.9
saaaa.aa	Antenna altitude
u	Altitude units, M=meters
±xxxx.x	Geoidal separation (requires geoidal height option)
M	Geoidal separation units, M = meters
sss	Age of differential corrections in seconds
aaaa	Base station identification
*cc	Checksum
<CR> <LF>	Carriage return and Line feed

GSA Data Message

The GSA message contains active satellites and PDOP value. The GSA message is given in the following form:

\$GPGSA,c1,d1,d2,d3,d4,d5,d6,d7,d8,d9,d10,d11,d12,d13,f1,f2,f3*cc<CR><LF>

Definition of GSA message components:

c1	Mode, M = manual, A = automatic
d1	Mode, 2 = 2D, 3 = 3D
d2-d13	Satellites used in position computation (range 0 to 32)
f1	PDOP (range 0 to 99.9)
f2	HDOP (range 0 to 99.9)
f3	VDOP (range 0 to 99.9)
*cc	Checksum
<CR><LF>	Carriage return and Line Feed

POS Data Message

The POS message contains the GPS position information and PDOP value. The POS message is given in the following form:

\$PASHR,POS,n,qq,hhmmss:ss,ddmm.mmmmm,s,dddmm.mmmmm,s,saaaa.aa,seeeee,ttt,ggg,svvv,pp,hh,vv,tt,vvv*cc<CR><LF>

Definition of POS message components:

n	Quality indicator, 0 = no differentially corrected position, 1 = differentially corrected position
qq	Number of satellites used in position computation
hhmmss:ss	UTC time in hours, minutes, seconds of the GPS position
ddmm.mmmmm	Latitude in degrees, minutes, and decimal minutes
s	s=N or s=S, for North and South latitude
dddmm.mmmmm	Longitude in degrees, minutes, and decimal minutes
s	s=E or s=W, for East and West longitude
saaaa.aa	sensor computed altitude
seeeee	reserved

ttt	True track/true course over ground in degree
ggg	Speed over ground (knots)
svvv	Vertical velocity (decimeters per second)
pp	PDOP - position dilution of precision (00 to 99)
hh	HDOP - horizontal dilution of precision (00 to 99)
vv	VDOP - vertical dilution of precision (00 to 99)
tt	TDOP - time dilution of precision (00 to 99)
vvvv	firmware version ID
*cc	Checksum
<CR><LF>	Carriage return and Line feed

LLK Data Message

The LLK (Leica Local Position and GDOP) message provides position in local coordinates in meters and GDOP value. The LLK message is given in the following form:

**\$GPKLLK,hhmmss.ss,ddmmyy,xxxx.xxxx,M,xxxx.xxxx,M,x,x,xx.xx,xxxx.xxxx,M,
*cc<CR><LF>**

Definition of LLK message components:

hhmmss.ss	UTC time in hours, minutes, seconds of the GPS position
ddmmyy	UTC date (day, month, year)
xxxx.xxxx	Grid Easting, meters
M	Meters (fixed text "M")
xxxx.xxxx	Grid Northing, meters
M	Meters (fixed text "M")
x	Quality indicator, 0 = not valid, 1 = GPS Nav Fix (no differentially corrected position), 2 = DGPS Fix (differentially corrected position), 3 = RTK Fix
x	Number of satellites used in computation,
xx.xx	GDOP
xxxx.xxxx	Height, meters
M	Meters (fixed text "M")
*cc	Checksum
<CR><LF>	Carriage return and Line feed

LLQ Data Message

The LLQ (Leica Local Position and Quality) message provides position in local coordinates in meters and position quality in meters. The LLQ message is given in the following form:

\$GPLLQ,hhmmss.ss,ddmmyy,xxxx.xxxx,M,xxxx.xxxx,M,x,x,xx.xx,xxxx.xxxx,M,*cc<CR><LF>

Definition of LLQ message components:

hhmmss.ss	UTC time in hours, minutes, seconds of the GPS position
ddmmyy	UTC date (day, month, year)
xxxx.xxxx	Grid Easting, meters
M	Meters (fixed text "M")
xxxx.xxxx	Grid Northing, meters
M	Meters (fixed text "M")
x	Quality indicator, 0 = not valid, 1 = GPS Nav Fix (no differentially corrected position), 2 = DGPS Fix (differentially corrected position), 3 = RTK Fix
x	Number of satellites used in computation,
xx.xx	Position quality, meters
xxxx.xxxx	Height, meters
M	Meters (fixed text "M")
*cc	Checksum
<CR><LF>	Carriage return and Line feed

GLL Data Message

The GLL message takes the following form:

\$GPGLL,ddmm.mmmmm,s,dddmm.mmmmm,s,hhmmss.ss,s*cc<CR><LF>

Definition of GLL message component:

dddmm.mmmmm	Latitude in degrees, minutes, and decimal minutes
s	s=N or s=S, for North and South latitude

dddmm.mmmmm	Longitude in degrees, minutes, and decimal minutes
s	s=E or s=W, for East and West longitude
hhmmss.ss	UTC time in hours, minutes, seconds of the GPS position
s	Status, A = valid, V = invalid
*cc	Checksum
<CR><LF>	Carriage return and Line feed

GGK Data Message

The GGK message contains the GPS position, Time, Date, Position Type, and DOP information. The GGK shown below is not a standard NMEA data message and it is used in several Trimble GPS receivers. If this message is used as a standard NMEA statement by a given GPS receiver it starts with \$GPGGK and contains GDOP instead of DOP.

TrackMaker software automatically recognizes which type of GGK message is used.

The Trimble proprietary type of GGK message takes the following form:

\$PTNL,GGK,hhmmss.ss,ddmmyy,ddmm.mmmmmmmmm,s,dddmm.mmmmmmmmm,s,n,qq,p,p,EHT-aa.aaa,M*cc<CR><LF>

Definition of GGK message component:

hhmmss.ss	UTC time in hours, minutes, seconds of the GPS position
ddmmyy	Date
ddmm.mmmmmmmmm	Latitude in degrees, minutes, and decimal minutes
s	s=N or s=S, for North and South latitude
dddmm.mmmmmmmmm	Longitude in degrees, minutes, and decimal minutes
s	s=E or s=W, for East and West longitude
n	GPS Quality indicator, 0 = fix not valid or not available, 1 = Autonomous GPS fix, no differentially corrected position, 2 = differential, floating carrier phase integer based solution (FLOAT), 3 = differential, fixed carrier phase integer-based solution (FIXED), 4 = differential, code phase only solution (DGPS)
qq	Number of satellites used in fix
p.p	DOP of fix

EHT-aa.aaa	Ellipsoidal height of fix
M	unit of measure for ellipsoidal height in meters
*cc	Checksum
<CR><LF>	Carriage return and Line feed

B.3 Configuring Trimble GPS Pathfinder ProXRS System

The data output in the Trimble Pathfinder ProXRS receiver can be configured in Asset Surveyor software in Trimble field computer (TSC1, TDC1, or TDC2). The Asset Surveyor Operation Manual provides details of the NMEA output format.

While running Asset Surveyor software select NMEA/TSIP output options from the Communication options menu. In the NMEA/TSIP output options form for Output select **NMEA**. After the NMEA option is selected Asset Surveyor extends the NMEA/TSIP form. Select Baud Rate: **9600** and Output interval: **1s** (or larger if required). Below these parameters a list of available NMEA-0183 messages will be displayed. Enable only required messages: GGA and GSA, or only GGA.

After you save the contents of the NMEA/TSIP output options form with the Output parameter set to **NMEA**, the Pathfinder GPS receiver begins to stream selected NMEA-0183 messages at the specified Output interval.